



PY32F040 Datasheet

32-bit ARM[®] Cortex[®]-M0+ Microcontroller



Puya Semiconductor (Shanghai) Co., Ltd



Features

- Core
 - ARM® 32-bit Cortex®-M0+ CPU
 - Up to 72 MHz operating frequency
- Memories
 - Maximum 128 Kbytes Flash memory
 - Maximum 16 Kbytes SRAM
- Clock management
 - Internal 4/8/16/22.12/24 MHz high speed clock (HSI)
 - Internal 32.768 kHz low speed clock (LSI)
 - External 4 to 32 MHz high speed crystal oscillator (HSE)
 - External 32.768 kHz low-speed crystal oscillator (LSE)
 - PLL (supports 2/3 multiplication of HSE)
- Power management and reset
 - Operating voltage: 1.7 to 5.5 V
 - Low power modes: Sleep and Stop
 - Power-on/power-down reset (POR/PDR)
 - Brown-out reset (BOR)
 - Programmable voltage detection (PVD)
- General-purpose input and output (I/O)
 - Up to 58 I/Os, all available as external interrupts
 - Drive current 8 mA
- 7-channel DMA controller
- One 12-bit ADC
 - Up to 16 external input channels
 - Input voltage conversion range: 0 to V_{CCA}
- 2 analog comparators
- 2-channel operational amplifier
- Support 8 * 36 / 4 * 40 LCD
- 13 timers
 - One 16-bit advanced-control timer (TIM1)
 - One 32-bit general-purpose timer (TIM2)
 - Five 16-bit general-purpose timers (TIM3/14/15/16/17)
 - Two basic timers (TIM6/TIM7)
 - A low power timer (LPTIM)
 - An independent watchdog timer (IWDG)
 - A window watchdog timer (WWDG)
 - A SysTick timer
- RTC
- Communication interfaces
 - Two serial peripheral interfaces (SPI) with I²S function
 - Four universal synchronous/asynchronous Transceivers (USARTs), support automatic baud rate detection, two of USARTs support ISO7816, LIN and IrDA
 - Two I²C interfaces supporting standard mode (100 KHz), Fast mode (400 KHz), 7-bit/10-bit addressing mode and SMBus
- Hardware CRC-32 module
- Hardware 32-bit divider
- Unique UID
- Serial wire debug (SWD)
- Operating temp.: - 40 ~ 85 °C, - 40 ~ 105 °C
- Package: LQFP64(12*12), LQFP64(10*10), LQFP48, QFN32(5*5), QFN32(4*4), QFN48

Contents

Features	2
1. Introduction	6
2. Functional Overview	10
2.1. Arm®-Cortex®-M0+ core	10
2.2. Memories	10
2.3. Boot modes	11
2.4. Clock system.....	11
2.5. Power management.....	13
2.5.1. Power block diagram.....	13
2.5.2. Power monitoring.....	13
2.5.3. Voltage regulator	14
2.5.4. Low-power mode.....	14
2.6. Reset.....	15
2.6.1. Power reset	15
2.6.2. System reset.....	15
2.7. General-purpose inputs and outputs (GPIOs)	15
2.8. Hardware divider (DIV)	15
2.9. Direct memory access controller (DMA)	15
2.10. Interrupts	16
2.10.1. Nested vectored interrupt controller (NVIC).....	16
2.10.2. Extended interrupt/event controller (EXTI).....	16
2.11. Analog-to-digital converter (ADC)	17
2.12. Comparators (COMP)	17
2.13. Operational amplifier (OPA).....	17
2.14. Liquid crystal display (LCD) controller	17
2.15. Timer	18
2.15.1. Advanced-control timer (TIM1).....	18
2.15.2. General-purpose timers.....	18
2.15.3. Basic timers (TIM6/TIM7).....	19
2.15.4. Low power timer (LPTIM).....	19
2.15.5. Independent watchdog (IWDG).....	19
2.15.6. System window watchdog (WWDG)	19
2.15.7. SysTick timer.....	19
2.16. Real-time clock (RTC).....	20
2.17. Cyclic redundancy check cell(CRC).....	20
2.18. System configuration controller (SYSCFG)	20
2.19. Debug support (DBG)	20
2.20. Inter-integrated circuit interface (I2C)	20
2.21. Universal synchronous/asynchronous receiver transmitter (USART).....	21

2.22.	Serial peripheral interface (SPI)	22
2.23.	Serial wire debug (SWD).....	22
3.	Pin Configuration.....	23
3.1.	PortA alternate function mapping.....	40
3.2.	PortB alternate function mapping.....	41
3.3.	PortC alternate function mapping	41
3.4.	PortF alternate function mapping.....	42
4.	Memory Map.....	43
5.	Electrical Characteristics.....	47
5.1.	Parameter conditions	47
5.1.1.	Minium and maximum values.....	47
5.1.2.	Typical values.....	47
5.2.	Absolute maximum ratings.....	47
5.3.	Operating conditions	48
5.3.1.	General operating conditions	48
5.3.2.	Operating conditions at power-up / power-down.....	48
5.3.3.	Embedded reset and LVD module features	48
5.3.4.	Operating current characteristics	49
5.3.5.	Wake-up time for low power mode.....	51
5.3.6.	External clock source characteristics	51
5.3.7.	Internal high frequency clock source HSI characteristics	53
5.3.8.	Internal low frequency clock source LSI characteristics	54
5.3.9.	Phase locked loop (PLL) characteristics	54
5.3.10.	Memory characteristics	54
5.3.11.	EFT characteristics.....	55
5.3.12.	ESD & LU characteristics	55
5.3.13.	Port characteristics	55
5.3.14.	NRST pin characteristics.....	56
5.3.15.	ADC characteristics	56
5.3.16.	Comparator characteristics	56
5.3.17.	Operational amplifier characteristics	57
5.3.18.	Temperature sensor characteristics	57
5.3.19.	Built-in reference voltage characteristics	58
5.3.20.	Timer characteristics	58
5.3.21.	Communication port characteristics	59
6.	Package Information	62
6.1.	LQFP64 (12*12) package size	62
6.2.	LQFP64(10*10) package size.....	63
6.3.	LQFP48 package size.....	64
6.4.	QFN48 package size	65

6.5. QFN32 (5*5) package size.....	66
6.6. QFN32 (4*4) package size.....	67
7. Ordering Information.....	68
8. Version History	69

Puya Confidential

1. Introduction

PY32F040 series microcontrollers incorporate high-performance ARM® 32-bit Cortex®-M0+ core, wide operating range voltage, embedded memories with up to 128 Kbytes flash and 32 Kbytes SRAM, frequency up to 72 MHz, and contains various products in different package types. The chip integrates multi-channel I²C, SPI, USART and other communication peripherals, one 12-bit ADC, 13 timers, two comparators, two operational amplifiers, and one LCD driver.

PY32F040 series microcontrollers 's operate in the temperature range from -40 to 85 °C or -40 to 105 °C ,and with operating voltages from 1.7 to 5.5 V. The chip provides sleep and stop low-power operating modes, which can meet different low-power applications.

The devices are suitable for various application scenarios, such as controllers, portable devices, PC peripherals, gaming and GPS platforms, industrial applications.

Table 1-1 PY32F040x6 series device features and peripheral counts

Peripherals		PY32F040R1B T6	PY32F040R2B T6	PY32F040C1B T6	PY32F040C18 T6	PY32F040C16 T6	PY32F040C1B U6	PY32F040K1B U6	PY32F040K2B U6
Flash (Kbytes)		128	128	128	64	32	128	128	128
SRAM (Kbytes)		16	16	16	8	4	16	16	16
Timers	Advanced	1 (16-bit)							
	General pupose	5 (16-bit)							
		1(32-bit)							
	Basic	2							
	low power	1							
	SysTick	1							
	Watchdog	2							
Comm. interfaces	SPI[I ² S]	2[2]							
	I ² C	2							
	USART	4							
DMA		7ch							
RTC		Yes							
GPIOs		58			42		42		28
12-bit ADC (external + internal)		1 (16 + 5)			1 (10 + 5)		1 (10 + 5)		1 (10 + 5)
Comparators		2							
OPA		2							
LCD		1							
Max. CPU frequency		72 MHz							
Operating Voltage		1.7 - 5.5 V							
Operating Temperature		- 40 – 85 °C							
Package		LQFP64(10*10)	LQFP64(12*12)	LQFP48			QFN48	QFN32(5*5)	QFN32(4*4)

Table 1-2 PY32F040x7 series device features and peripheral counts

Peripherals		PY32F040C1BT7
Flash (Kbytes)		128
SRAM (Kbytes)		16
Timers	Advanced	1 (16-bit)
	General pupose	5 (16-bit)
		1(32-bit)
	Basic	2
	low power	1
	SysTick	1
Watchdog	2	
Comm. interfaces	SPI[I ² S]	2[2]
	I ² C	2
	USART	4
DMA		7ch
RTC		Yes
GPIOs		42
12-bit ADC (external + internal)		1 (10 + 5)
Comparators		2
OPA		2
LCD		1
Max. CPU frequency		72 MHz
Operating Voltage		1.7 ~ 5.5 V
Operating Temperature		- 40 ~ 105 °C
Package		LQFP48

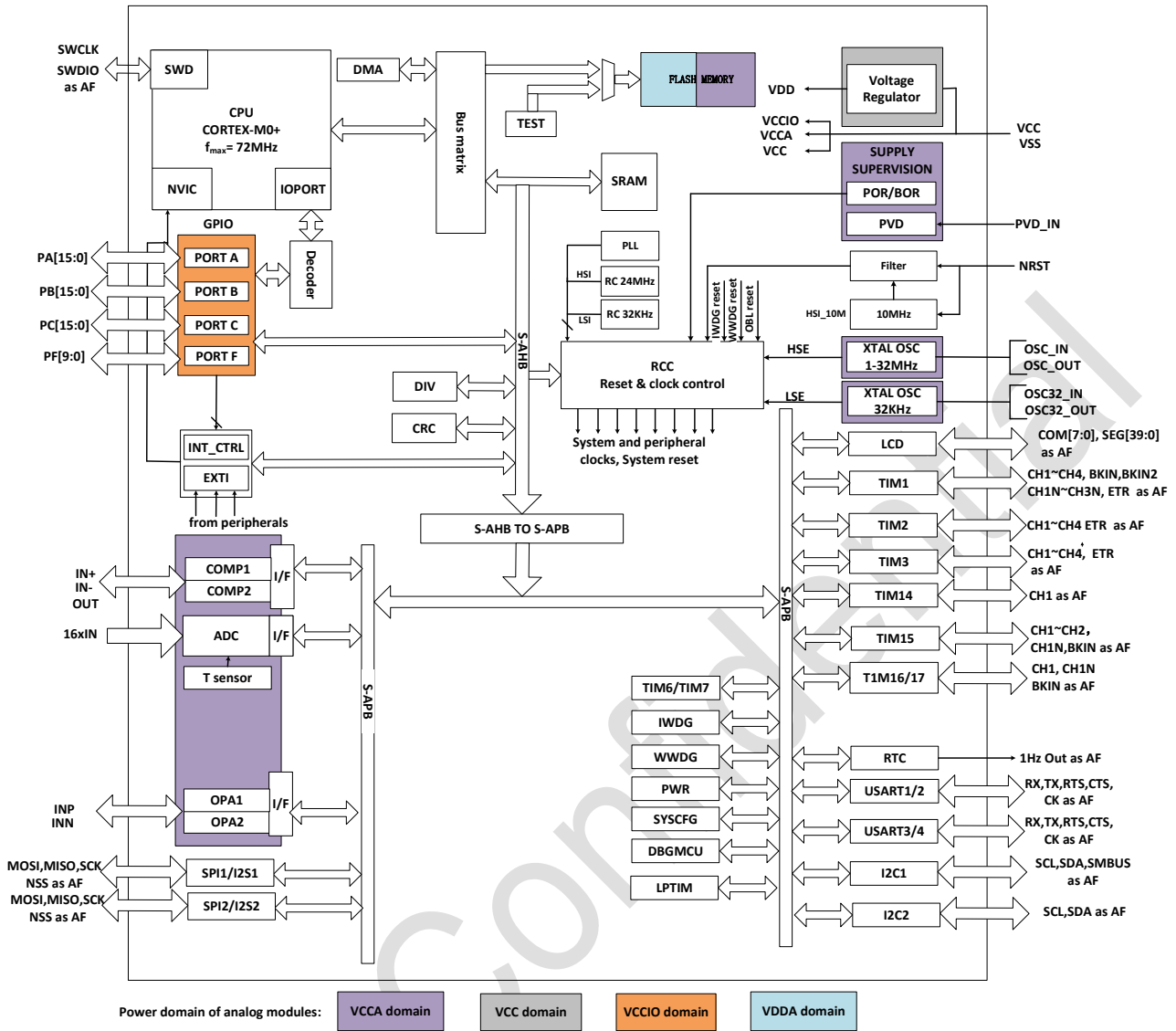

Figure 1-1 System block diagram

2. Functional Overview

2.1. Arm®-Cortex®-M0+ core

The Arm® Cortex®-M0+ is an entry-level Arm 32-bit Cortex processor designed for a wide range of embedded applications. It provides developers with significant benefits, including:

- Simple structure, easy to learn and program
- Ultra-low power consumption, energy-saving operation
- Reduced code density and more

Cortex-M0+ processor is a 32-bit core optimized for area and power consumption and is a 2-stage pipeline Von Neumann architecture. The processor offers high-end processing hardware, including single-cycle multipliers, through a streamlined but powerful instruction set and an extensively optimized design. Moreover, it delivers the superior performance expected from a 32-bit architecture computer, with a higher coding density than other 8 and 16-bit microcontrollers.

The Cortex-M0+ is tightly coupled with a Nested Vectored Interrupt Controller (NVIC).

2.2. Memories

The on-chip integrated SRAM is accessed by bytes (8 bits), half-word (16 bits) or word (32 bits).

The on-chip integrated Flash consists of two different physical areas:

- Main flash area contains application and user data
- Information area has 14 Kbytes, and it includes the following parts:
 - Option bytes
 - UID bytes
 - System memory

The protection of Flash main memory includes the following mechanisms:

- Read protection (RDP) prevents outside access.
- Write protection (WRP) prevents unwanted write operation (confuse by program memory pointer from PC). The minimum protection unit for write protection is 8 Kbytes.
- Option byte write protection is a special design for unlock.

2.3. Boot modes

At startup, the BOOT0 pin and boot selector option bit nBOOT are used to select one of the three boot options in the following table:

Table 2-1 Boot configuration

Boot mode configuration		Mode
nBOOT1 bit	BOOT0 pin	
X	0	Main Flash as the boot area
1	1	System memory as the boot area
0	1	SRAM as the boot area

The Boot loader is located in the System memory and is used to download the Flash program through the USART interface.

2.4. Clock system

At startup, the default system clock frequency is HSI 8 MHz, and after the program is operating the system clock frequency and system clock source can be reconfigured. The high frequency clocks that can be selected are:

- A 4/8/16/22.12/24 MHz configurable internal high precision HSI clock
- A 32.768 kHz configurable internal LSI clock
- A 4 to 32 MHz HSE clock, and used to enable the CSS function to detect HSE. If CSS fails, the hardware will automatically convert the system clock to HSI, and software configures the HSI frequency. Simultaneously, CPU NMI interrupt is generated.
- A 32.768 kHz LSE clock.
- PLL clock has HSI and HSE sources. If the HSE source is selected, when CSS is enabled and CSS fails, the PLL and HSE will be turned off, and the hardware selects the system clock source as HSI.

The AHB clock can be divided based on the system clock, and the APB clock can be divided based on the AHB clock. AHB and APB clock frequencies up to 72 MHz.

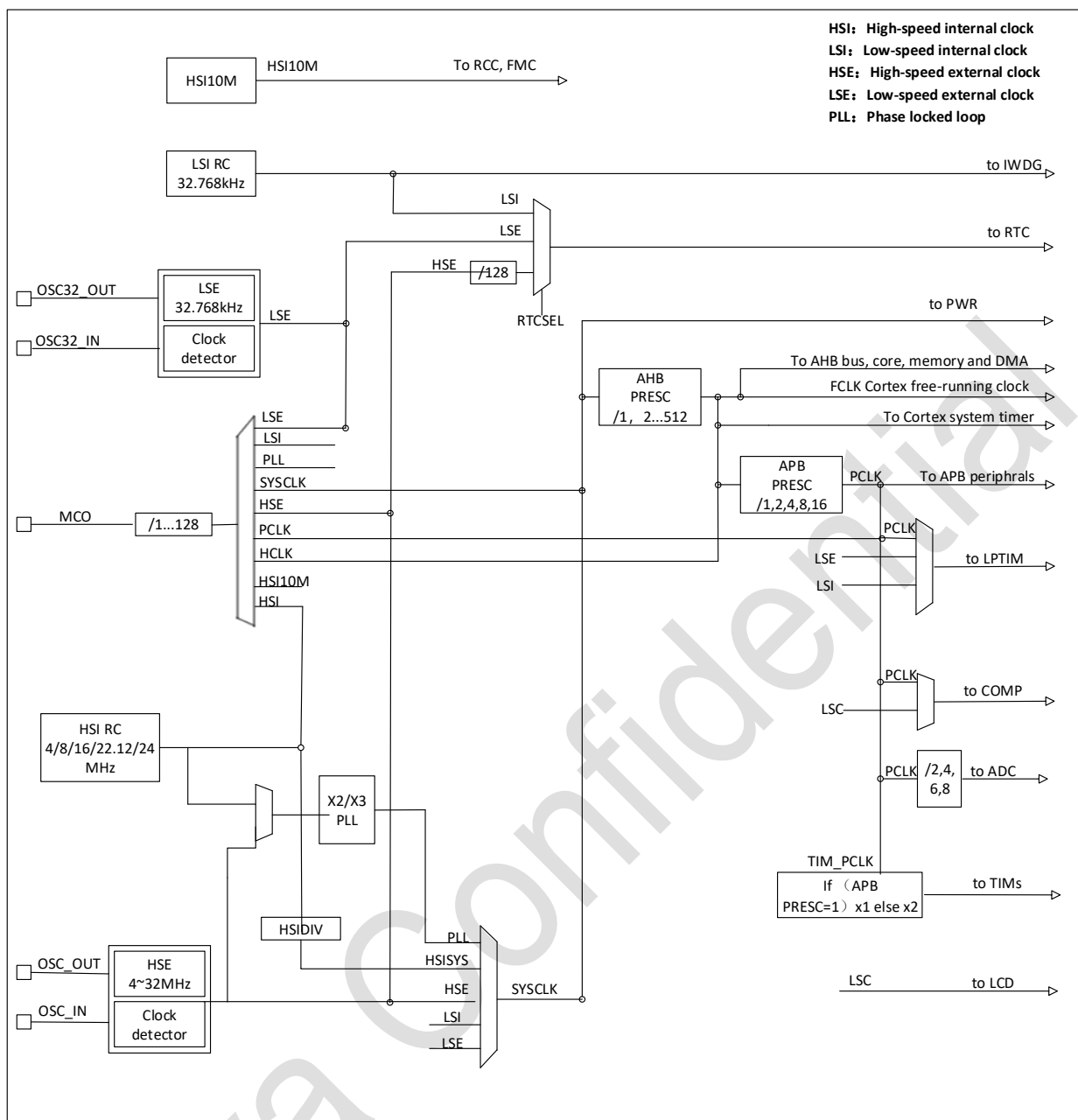

Figure 2-1 System Clock Structure Diagram

2.5. Power management

2.5.1. Power block diagram

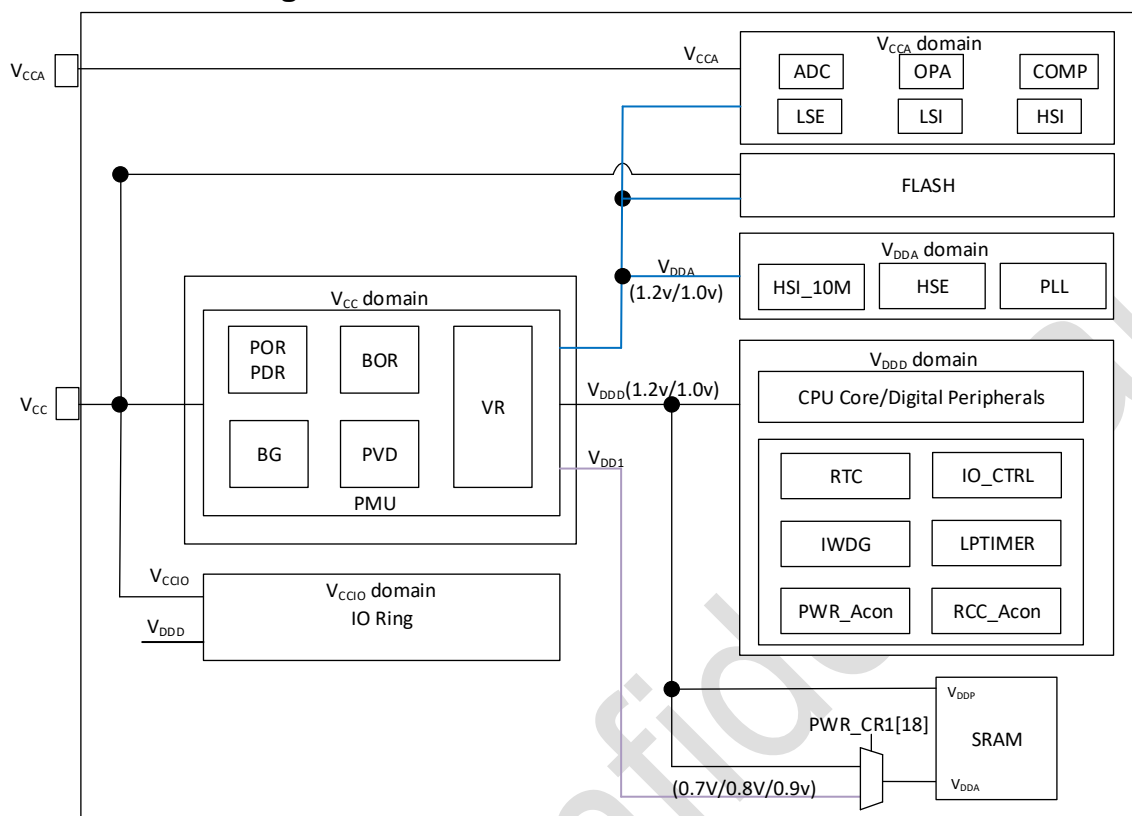

Figure 2-2 Power block diagram

Table 2-2 Power Block Diagram

No.	Power supply	Power value	Describe
1	V _{CC}	1.7 to 5.5 V	The chip is supplied power through the power pins.
2	V _{DDD}	1.2/1.0 V ± 10 %	VR supplies power to the main logic circuits and SRAM inside the chip. When the MR is powered, it outputs 1.2 V. According to the software configuration, when entering the stop mode it powered by MR or LPR, and the LPR output is determined to be 1.2 V or 1.0 V.
3	V _{CCA}	1.7 to 5.5 V	The chip is supplied analog power through the power pins.

2.5.2. Power monitoring

2.5.2.1. Power on reset (POR/PDR)

The power-on reset (POR) and power-down reset (PDR) module is designed in the chip to provide power-on and power-off reset for the chip. The module keeps working in all modes.

2.5.2.2. Brown-out reset (BOR)

In addition to POR/ PDR, BOR (brown-out reset) is also implemented. BOR can only be enabled and disabled through the option byte.

When the BOR is turned on, the BOR threshold can be selected by the Option byte, and both the rising and falling detection points can be configured individually.

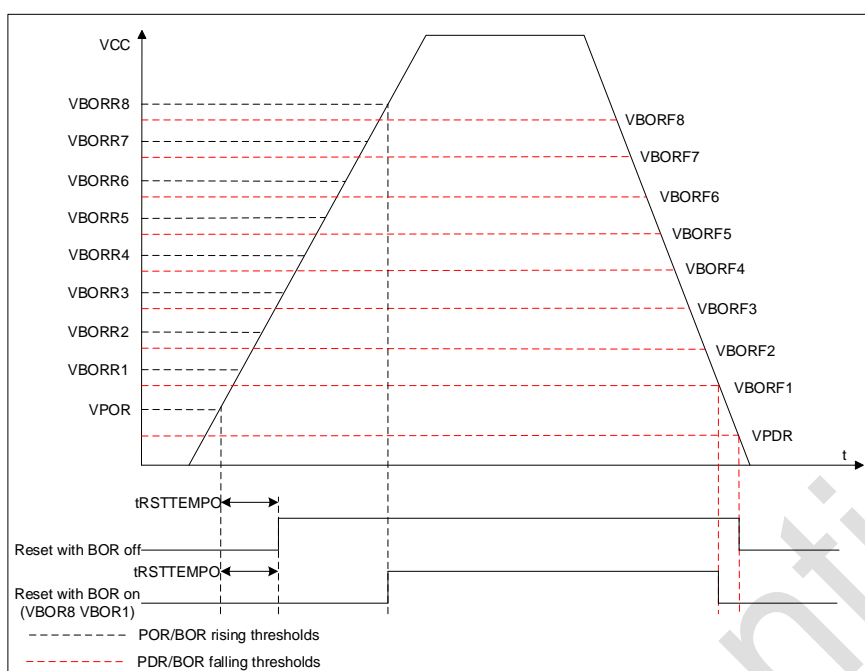

Figure 2-3 POR/PDR/BOR threshold

2.5.2.3. Programmable voltage detection (PVD)

Programmable voltage detector (PVD) module can be used to detect the V_{CC} power supply and the voltage of the PB7 pin, and the detection point is configured through the register. When V_{CC} is higher or lower than the detection point of PVD, the corresponding reset flag is generated.

This event is internally connected to line 16 of EXTI, depending on the rising/falling edge configuration of EXTI line 16, when V_{CC} rises above the detection point of PVD, or V_{CC} falls below the detection point of PVD, an interrupt is generated. In the service program, users can perform urgent shutdown tasks.

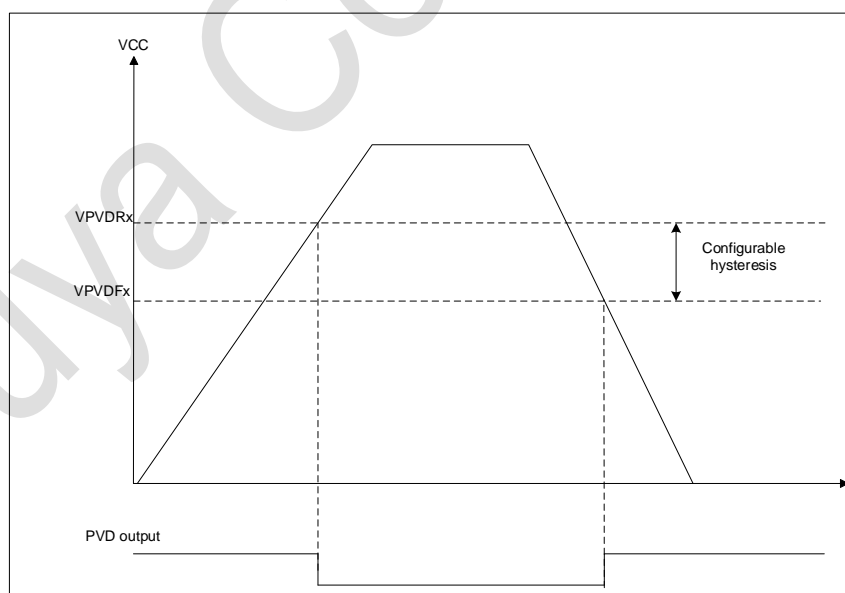

Figure 2-4 PVD threshold

2.5.3. Voltage regulator

The regulator has two operating modes:

- Main regulator (MR) is used in normal operating mode.
- Low power regulator (LPR) can be used in Stop mode where the power demand is reduced.

2.5.4. Low-power mode

In addition to the normal operating mode, the chip has 2 low-power modes:

- Sleep mode: Peripherals can be configured to keep working when the CPU clock is off (NVIC, SysTick, etc.). It is recommended only to enable the modules that must work, and close the module after the module works.
- Stop mode: In this mode, the contents of SRAM and registers are maintained, HSI and HSE are turned off, and most modules of clocks in the V_{DD} domain are stopped. GPIO, PVD, COMP output, RTC and LPTIM can wake up stop mode.

2.6. Reset

Two resets are designed in the chip: power reset and system reset.

2.6.1. Power reset

A power reset occurs in the following situations:

- Power-on/power-down reset (POR/PDR)
- Brown-out Reset (BOR)

2.6.2. System reset

A system reset occurs when the following events occur:

- Reset of NRST pin
- Windowed watchdog reset (WWDG)
- Independent watchdog reset (IWDG)
- SYSRESETREQ software reset
- Option byte load reset (OBL)

2.7. General-purpose inputs and outputs (GPIOs)

Each of the GPIO pins can be configured by software as output (push-pull or open-drain), as input (with or without pull-up or pull-down) or as peripheral alternate function, locking mechanism will freeze I/Os configuration function.

- Register support IO Port / AHB bus read/write
- Output state: push-pull or open-drain output + pull-up/pull-down
- Data output from data register (GPIOx_ODR) or peripheral (multiplexed function output)
- Speed selectable per I/O
- Input states: float, pull-up/pull-down, analogue
- Data input to input data register (GPIOx_IDR) or peripheral (multiplexed function input)
- Bit position/reset register (GPIOx_BSRR), allows bit write access to GPIOx_ODR
- Lockout mechanism (GPIOx_LCKR) freezes I/O port configuration functions
- Analogue function
- Multiplexing function selection register (up to 16 multiplexing functions per IO port)
- Fast flip-flop capability in a single cycle
- Highly flexible I/O multiplexing function, allowing the I/O port to function as a GPIO or as an interface to various peripherals

2.8. Hardware divider (DIV)

Hardware divider is a 32-bit signed/unsigned integer hardware divider.

DIV features:

- Configurable signed/unsigned integer division calculation
- 32-bit dividend, 32-bit divisor
- Output 32-bit quotient and 32-bit remainder
- Division zero warning flag, division end flag
- 8 clock cycles to complete a division operation
- Write the divisor register to trigger the division operation to start
- Automatically wait for the end of the calculation when reading the quotient register/remainder register

2.9. Direct memory access controller (DMA)

Direct memory access (DMA) is used to provide high-speed data transfer between peripherals and memory or between memory and memory. Data can be moved quickly through DMA without CPU intervention, which saves CPU resources for other operations. The DMA controller has seven channels, each dedicated to managing requests for memory access from one or more peripherals. There is also a mediator to coordinate the priority of individual DMA requests.

The main functions are as follows:

- Single AHB master
- Support peripherals to memory, the memory to the peripherals, memory to memory and peripherals to peripheral data transmission
- On-chip memory devices, such as FLASH, an SRAM, AHB and APB peripherals, as the source and target
- All DMA channel can be independent configuration:
 - Each channel is associated either with a DMA request signal from a peripheral or with a software trigger in a memory-to-memory transfer. This configuration is done by software.
 - The priority between requests is programmable by software (4 levels per channel: very high, high, medium, low) and, in equal cases, by hardware (such as a request for channel 1 taking precedence over a request for channel 2).
 - The transfer sizes of the source and destination are independent (byte, half word, word), simulating packing and unpacking. The source and destination addresses must be aligned by data size.
 - Programmable data transmission: 0 ~ 65535
- Each channel generates an interrupt request. Each interrupt request is caused by one of three DMA events: transfer completion, half-transfer, or transfer error.

2.10. Interrupts

The PY32F040 handles exceptions through the Cortex-M0+ processor's embedded a nested vectored interrupt controller (NVIC) and an extended interrupt/event controller (EXTI).

2.10.1. Nested vectored interrupt controller (NVIC)

NVIC is a tightly coupled IP inside the Cortex-M0+ processor. The NVIC can handle NMI (Non-Maskable Interrupts) and maskable external interrupts from outside the processor and Cortex-M0+ internal exceptions. NVIC provides flexible priority management.

The tight coupling of the processor core to the NVIC greatly reduces the delay between an interrupt event and the initiation of the corresponding interrupt service routine (ISR). The ISR vectors are listed in a vector table, stored at a base address of the NVIC. The vector table base address determines the vector address of the ISR to execute, and the ISR is used as the offset composed of serial numbers.

If a high-priority interrupt event occurs and a low-priority interrupt event is just waiting to be serviced, the later-arriving high-priority interrupt event will be serviced first. Another optimization is called tail-chaining. When returning from a high-priority ISR and then starting a pending low-priority ISR, unnecessary pushes and pops of processor contexts will be skipped. This reduces latency and improves power efficiency.

NVIC features:

- Low latency interrupt handling
- Level 4 interrupt priority
- Supports one NMI interrupt
- Support 32 maskable external interrupts
- High-priority interrupts can interrupt low-priority interrupt responses
- Support tail-chaining optimization
- Hardware interrupt vector retrieval

2.10.2. Extended interrupt/event controller (EXTI)

EXTI adds flexibility to handle physical wire events and generates wake-up events when the processor wakes up from stop mode.

The EXTI controller has multiple channels, including a maximum of 16 GPIOs, 1 PVD output, 2 COMP outputs, RTC and LPTIM wake-up signals. GPIO, PVD and COMP can be configured to be triggered

by a rising edge, falling edge or double edge. Any GPIO signal can be configured as EXTI0 to 15 channel through the select signal.

- Each EXTI line can be independently masked through registers.
- The EXTI controller can capture pulses shorter than the internal clock period.
- Registers in the EXTI controller latch each event. Even in stop mode, after the processor wakes up from stop mode, it can identify the wake-up source or identify the GPIO and event that caused the interrupt.

2.11. Analog-to-digital converter (ADC)

The chip has a 12-bit SARADC. The module has up to 21 channels to be measured, including 16 external channels and 5 internal channels. The reference voltage can be selected from the supply voltage.

- The conversion mode of each channel can be set to single, continuous, sweep, discontinuous mode. Conversion results are stored in left or right-aligned 16-bit data registers.
- An analogue watchdog allows the application to detect if the input voltage exceeds a user-defined high or low threshold.
- The ADC has been implemented to operate at a low frequency, resulting in lower power consumption.
- At the end of sampling, conversion, and continuous conversion, an interrupt request is generated when the conversion voltage exceeds the threshold when simulating the watchdog.

2.12. Comparators (COMP)

Three general purpose comparators are integrated in the chip, namely COMP1/2. It can be used as a separate module or in combination with timer.

Comparators can be used as follows:

- Triggered by analog signal to generate low-power mode wake-up function
- Analog signal conditioning
- Cycle by cycle current control loop when connected with PWM output from timer

2.13. Operational amplifier (OPA)

The OPA1/2 module can be flexibly configured and is suitable for simple amplifiers. The three internal opamps can be cascaded using external resistors.

OPA features are summarized as follows:

- Three independently configured operational amps
- OPA input range is 0 to AV_{CC} , output range is 0.1 V to $AV_{CC} - 0.2$ V (demand) to simulate a module, a programmable gain
- Can be configured for the following models
 - General operational mode (general purpose OPA)

2.14. Liquid crystal display (LCD) controller

The LCD controller is a digital controller/driver for monochrome passive liquid crystal displays (LCDS), with up to 8 common terminals (COM) and 40 segment terminals (SEG) to drive 160 (4 * 40) or 288 (8 * 36) LCD image elements. The exact number of terminals depends on the device pins described in the data manual. LCD functions are summarized as follows:

- Highly flexible frame rate control
- support static, 1/2, 1/3, 1/4, 1/6, and 1/8 of a duty ratio
- support 1/2, 1/3 bias voltage
- up to 16 registers LCD data RAM
- by software configuration of LCD contrast
- 3 kinds of waveform generation
 - internal resistance pressure resistance, external pressure, external capacitance partial pressure
 - by way of internal resistance of the software configuration partial pressure power consumption, so as to match the capacitance charge needed for the LCD panel

- support low power consumption modes: LCD controller can be on the run, Sleep and stop mode for display
- configurable frame interrupt
- support LCD flashing function and configuration of multiple flicker frequency
- unused LCD segments and public pin can be configured to digital or analog functions

2.15. Timer

The characteristics of different timers of PY32F040 series are shown in the following table:

Table 2-3 Timer features comparison

Timer type	Timer	Counter resolution	Counter type	Prescaler factor	DMA	Capture /compare channels	Complementary outputs
Advanced control	TIM1	16-bit	Up, down, center aligned	Integer from 1 to 65536	Support	4	3
General purpose	TIM2	32-bit	Up, down, center aligned	Integer from 1 to 65536	Support	4	-
General purpose	TIM3	16-bit	Up, down, center aligned	Integer from 1 to 65536	Support	4	-
	TIM14	16-bit	Up	Integer from 1 to 65536	-	1	-
	TIM15	16-bit	Up	Integer from 1 to 65536	-	2	1
	TIM16, TIM17	16-bit	Up	Integer from 1 to 65536	Support	1	1
Basic	TIM6, TIM7	16-bit	Up	Integer from 1 to 65536	Support	-	-

2.15.1. Advanced-control timer (TIM1)

The advanced-control timer (TIM1) is consist of a 16-bit auto-reload counter driven by a programmable prescaler. It can be used in various scenarios, including pulse length measurement of input signals (input capture) or generating output waveforms (output compare, output PWM, complementary PWM with dead-time insertion).

TIM1 includes 4 independent channels:

- Input capture
- Output comparison
- PWM generation (edge or center-aligned mode)
- Single pulse mode output

If TIM1 is configured as a standard 16-bit timer, it has the same features as the TIMx timer. If configured as the 16-bit PWM generator, it has full modulation capability (0-100%).

The counter can be frozen in debug mode.

Many features are shared with those of the standard timers which have the same architecture. The advanced control timer can therefore work together with the other timers by the Timer Link feature for synchronization or event chaining.

TIM1 supports the DMA function.

2.15.2. General-purpose timers

2.15.2.1. TIM2/TIM3

The general-purpose timers TIM2/TIM3 are consist of 32/16-bit auto-reload counters and a 32/16-bit prescaler. There are four independent channels each for input capture/output compare, PWM or one-pulse mode output.

- They can work with the TIM1 by the Timer Link.
- TIM2/TIM3 supports DMA function.
- This timer is capable of handling quadrature (incremental) encoder signals and the digital outputs from 1 to 3 hall-effect sensors.

- The counter can be frozen in debug mode.

2.15.2.2. TIM14

- The general-purpose timer (TIM14) is consist of a 16-bit auto-reload counter driven by a programmable prescaler.
- TIM14 features one single channel for input capture/output compare, PWM or one-pulse mode output.
- The counter can be frozen in debug mode.

2.15.2.3. TIM15/TIM16/TIM17

- The general-purpose timer (TIM15, TIM16 and TIM17) is consist of a 16-bit auto-reload counter driven by a programmable prescaler.
- TIM16/TIM17 features one single channel for input capture/output compare, PWM or one-pulse mode output.
- TIM15 features two single channel for input capture/output compare, PWM or one-pulse mode output.
- TIM15/TIM16/TIM17 have complementary outputs with dead time.
- TIM15/TIM16/TIM17 supports DMA function.
- The counter can be frozen in debug mode.

2.15.3. Basic timers (TIM6/TIM7)

- The basic timer (TIM6/TIM7) is consist of a 16-bit auto-reload upcounter driven by their programmable prescaler respectively.
- Generate interrupt/DMA request on update event (counter overflow).

2.15.4. Low power timer (LPTIM)

- LPTIM is a 16 -bit upcounter with a 3-bit prescaler and only support a single count.
- LPTIM can be configured as a stop mode wake-up source.
- The counter can be frozen in debug mode.

2.15.5. Independent watchdog (IWDG)

Independent watchdog (IWDG) is integrated in the chip, and this module has the characteristics of high-security level, accurate timing and flexible use. IWDG finds and resolves functional confusion due to software failure and triggers a system reset when the counter reaches the specified timeout value.

- The IWDG is clocked by LSI, so even if the main clock fails, it can keep working.
- IWDG is the best suited for applications that require the watchdog as a standalone process outside of the main application and do not have high timing accuracy constraints.
- Controlling of option byte can enable IWDG hardware mode.
- IWDG is the wake-up source of stop mode, which wakes up stop mode by reset.
- The counter can be frozen in debug mode.

2.15.6. System window watchdog (WWDG)

The system window watchdog is based on a 7-bit downcounter that can be set as free running. It can be used as a watchdog to reset the device when a problem occurs. It is clocked from the APB clock (PCLK). It has an early warning interrupt capability, and the counter can be frozen in debug mode.

2.15.7. SysTick timer

SysTick timer is dedicated to real-time operating systems, but could also be used as a standard downcounter.

SysTick Features:

- 24-bit down counter
- Auto-reload capability
- Maskable system interrupt generation when the counter reaches 0

2.16. Real-time clock (RTC)

The real-time clock is an independent counter. It has a set of continuous counting counters, which can provide a clock calendar function under the corresponding software configuration. Modifying the value of the counter can reset the current time and date of the system.

- RTC is a 32-bit programmable counter with a prescale factor of up to 2^{20} bits.
- The RTC counter clock source can be LSE/LSI and the stop wake-up source.
- RTC can generate alarm interrupt, second interrupt and overflow interrupt (maskable).
- RTC supports clock calibration.
- RTC can be frozen in debug mode.

2.17. Cyclic redundancy check cell(CRC)

CRC computing unit is based on a fixed generation polynomial to obtain 32-bit CRC computing results. In other applications, CRC technology is mainly used to verify the correctness and integrity of data transmission or data storage. CRC cell contains one 32-bit data register:

- When writing to this register, as an input register, you can enter new data to perform CRC calculations.
- When the register is read, the result of the last CRC calculation is returned.
- Each time a data register is written, the result of the calculation is a combination of the previous CRC calculation and the new calculation (CRC calculation is performed on the entire 32-bit word rather than byte by byte).
- You can RESET register CRC_DR to 0xFFFF by setting the reset bit of register CRC_CR. This operation does not affect the data in register CRC_IDR.
- The initial CRC value can be configured.

2.18. System configuration controller (SYSCFG)

The SYSCFG module provides the following functions:

- The filtering function on the IO pin of the I^2C type was enabled or disabled
- Enable or disable filtering on all I/O pins
- Remap trigger sources for some Dmas to different DMA channels
- Remap memory at the beginning of the code interval (Boot)
- Manages the TIMERS ETR or brake input

2.19. Debug support (DBG)

The MCU DBG module assists the debugger with the following functions:

- Support sleep mode, stop mode and standby mode
- When the CPU enters the HALT mode, the control timer or watchdog stops counting or continues counting
- Block I^2C1 and I^2C2 SMBUS timeouts when the CPU is in HALT mode
- Assign tracking pins
- The MCUIDBG register also provides chip ID encoding. This ID encoding can be accessed by a JTAG or SW debug interface, or by a user program.

2.20. Inter-integrated circuit interface (I2C)

I^2C (inter-integrated circuit) bus interface connects the microcontroller and the serial I^2C bus. It provides multi-master capability and controls all I^2C bus specific sequences, protocols, arbitration and timing. Standard mode (Sm) and fast mode (Fm) are supported.

I^2C Features:

- Two I^2C Interface, support slave and master mode
- Multi-host function: can be master or slave
- Support different communication speeds
 - Standard Mode (Sm): Up to 100 KHz
 - Fast Mode (Fm): up to 400 KHz
- As master

- Generate Clock
- Generation of Start and Stop
- As slave
 - Programmable I²C address detection
 - Dual-address capability that responds to two secondary addresses
 - Discovery of the Stop bit
- 7-bit/10-bit addressing mode
- General call
- Status flag
 - Transmit/receive mode flags
 - Byte transfer complete flag
 - I²C busy flag bit
- Error flag
 - Master arbitration loss
 - ACK failure after address/data transfer
 - Start/Stop error
 - Overrun/Underrun (clock stretching function disable)
- Optional clock stretching
- Single-byte buffer with DMA capability
- Software reset
- Analog noise filter function
- Support SMBus

2.21. Universal synchronous/asynchronous receiver transmitter (USART)

PY32F040 contains 4 USARTs, supports ISO7816, LIN, IrDA.

The USARTs provide a flexible method for full-duplex data exchange with external devices using the industry-standard NRZ asynchronous serial data format. The USART utilizes a fractional baudrate generator to provide a wide range of baudrate options.

It supports simultaneous one-way communication and half-duplex single-wire communication, and it also allows multi-processor communication.

Automatic baudrate detection is supported.

High-speed data communication can be achieved by using the DMA method of the multi-buffer configuration.

USARTs features:

- Full-duplex asynchronous communication
- NRZ standard format
- Configurable 16 times or 8 times oversampling for increased flexibility in speed and clock tolerance
- Programmable baudrate shared by transmit and receive, up to 4.5 Mbit/s
- Automatic baudrate detection
- Programmable data length of 8 or 9 bits
- Configurable stop bits (0.5, 1, 1.5 or 2 bits)
- Synchronous mode and clock output function for synchronous communication
- Single-wire half-duplex communication
- Independent transmit and receive enable bits
- Hardware flow control
- Receive/transmit bytes by DMA buffer
- Detection flag
 - Receive full buffer
 - Send empty buffer
 - End of transmission
- Parity control
 - Send check digit
 - Check the received data
- Flagged interrupt sources
 - CTS change
 - Send empty register
 - Send completed

- Receive full data register
- Bus idle detected
- Overflow error
- Frame error
- Noise operation
- Error detection
- Multiprocessor communication
 - If the address does not match, enter silent mode
- Wake-up from silent mode: by idle detection and address flag detection

2.22. Serial peripheral interface (SPI)

PY32F040 contains two SPIs. SPIs allow the chip to communicate with external devices in half-duplex, full-duplex, and simplex synchronous serial communication. This interface can be configured in master mode and provides the communication clock (SCK) for external slave devices. The interface can also work in a multi-master configuration.

The SPI features are as follows:

- Master or slave mode
- 3-wire full-duplex simultaneous transmission
- 2-wire half-duplex synchronous transmission (with bidirectional data line)
- 2-wire simplex synchronous transmission (no bidirectional data line)
- 8-bit or 16-bit transmission frame selection
- Support multi-master mode
- 8 master mode baud rate prescale factors (max $f_{PCLK}/2$)
- Slave mode frequency (max $f_{PCLK}/4$)
- Both master and slave modes can be managed by software or hardware NSS: dynamic change of master/slave operating mode
- Programmable clock polarity and phase
- Programmable data order, MSB first or LSB first
- Dedicated transmit and receive flags that can trigger interrupts
- SPI bus busy status flag
- Motorola mode
- Interrupt-causing master mode faults, overloads
- Two 32-bit Rx and Tx FIFOs with DMA capability

2.23. Serial wire debug (SWD)

The ARM SWD interface allows serial debugging tools to be connected to the PY32F040.

3. Pin Configuration

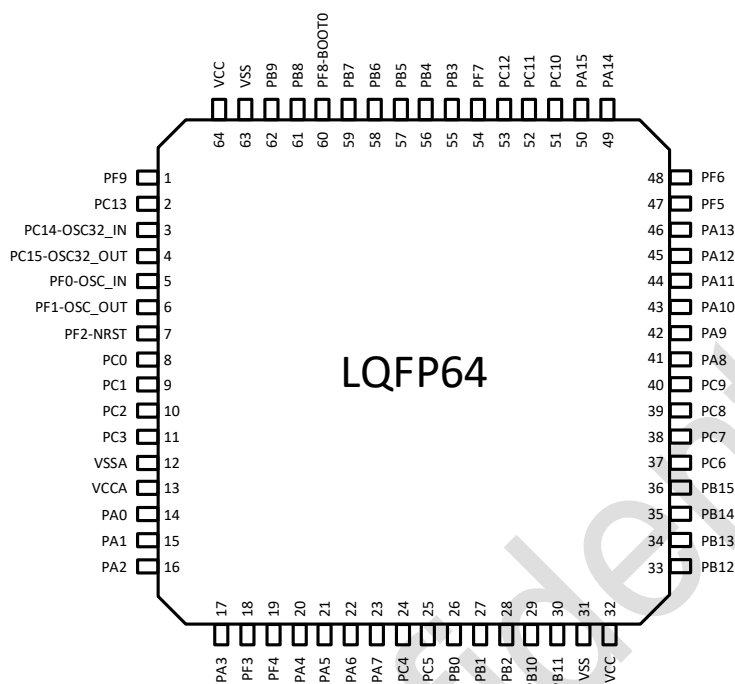

Figure 3-1 LQFP64(10*10) PY32F040R1xT6 Pinout1(Top view)

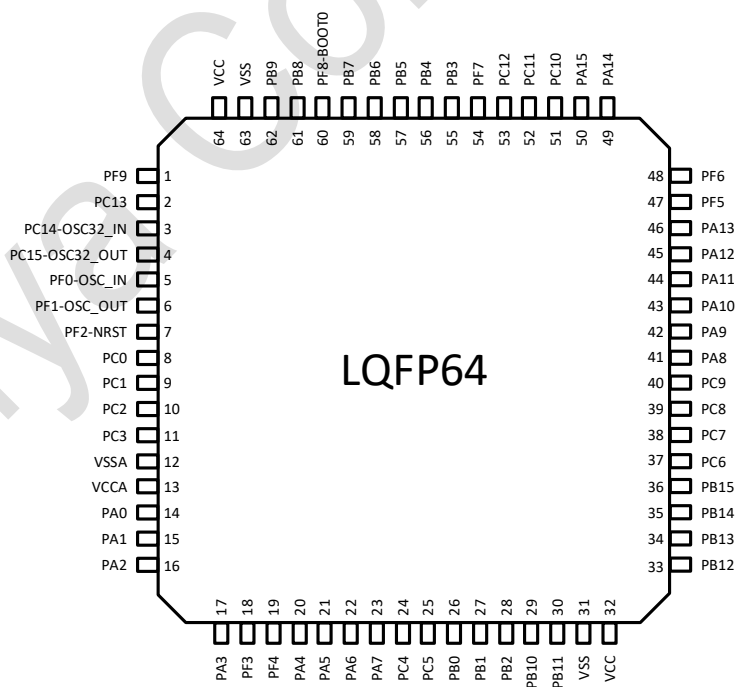

Figure 3-2 LQFP64(12*12) PY32F040R2xT6 Pinout2(Top view)

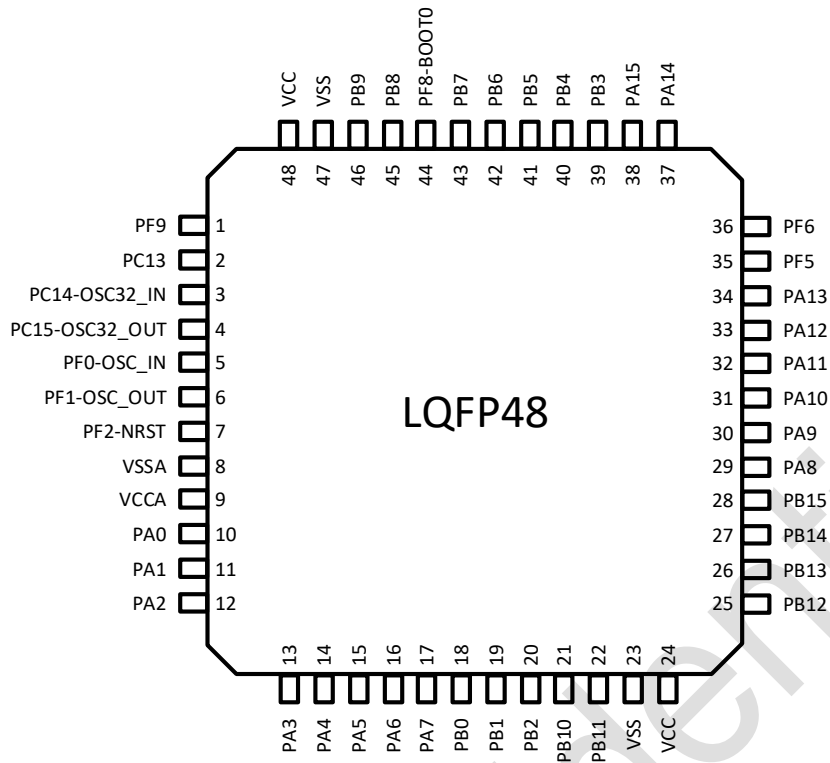

Figure 3-3 LQFP48 PY32F040C1xTx Pinout1(Top view)

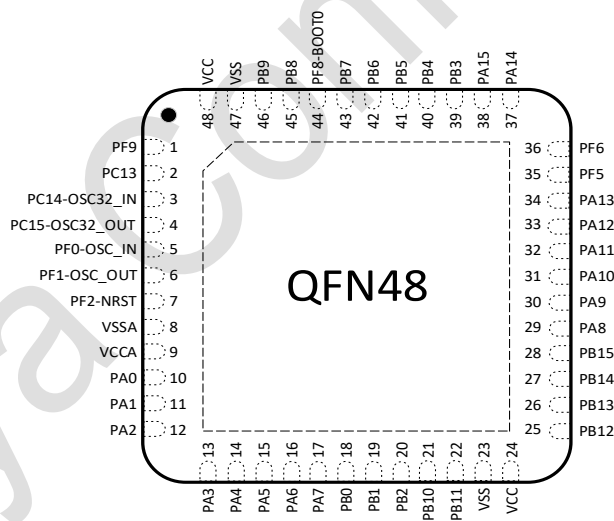

Figure 3-4 QFN48 PY32F040C1xU6 Pinout1(Top view)

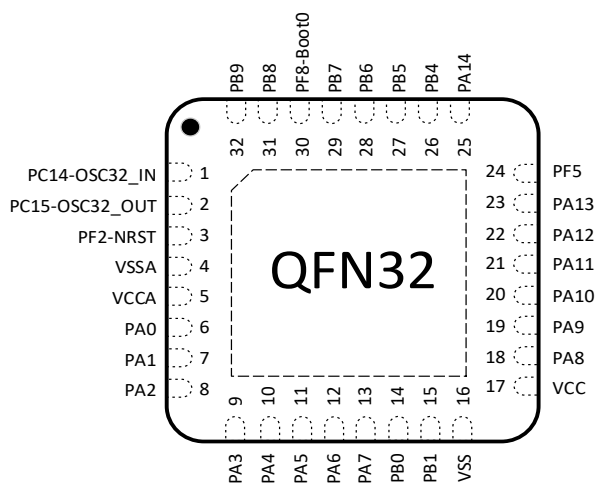

Figure 3-5 QFN32(5*5) PY32F040K1xU6 Pinout1(Top view)

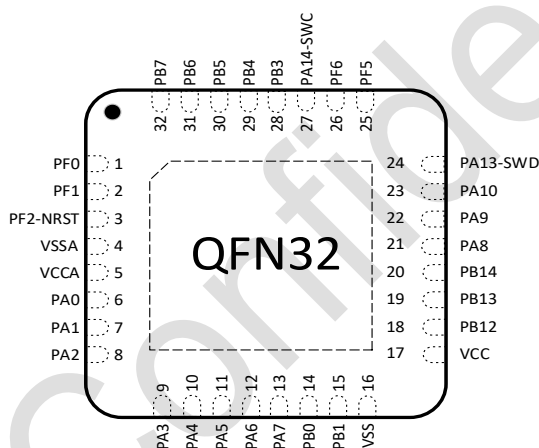

Figure 3-6 QFN32(4*4) PY32F040K2xU6 Pinout2(Top view)

Table 3-1 Pin Definition Terminology and Symbols

Name		Symbol	Definition
Pin type		S	Supply pin
		G	Ground pin
		I	Input-only pin
		I/O	Input/output pin
I/O structure		COM	Normal 5 V I/O with analog input and output function
		RST	Reset pin, with internal weak pull-up resistor, without analog input and output function
		COM_F	I/O, I ² C Fm+ capable with analog input and output function
		COM_U	GPIO 5V tolerant with USB PHY function
Notes		-	Unless otherwise specified, all ports are used as floating inputs between and after reset
Pin function	Alternate functions	-	Function selected by GPIOx_AFR register
	Additional functions	-	Directly selected or enabled through peripheral registers

Table 3-2 Pin definition

Package					Reset	Ports Type	Ports structure	Notes	Pin functions	
LQFP64 R1 /R2	LQFP48 C1	QFN48 C1	QFN32 (5*5) K1	QFN32 (4*4) K2					Alternate functions	Additional functions
1	1	1	-	-	PF9	I/O	COM	-	-	-
2	2	2	-	-	PC13	I/O	COM	-	SPI1_SCK/I ² S1_CK	-
3	3	3	1	-	PC14	I/O	COM	-	TIM1_BKIN	OSC32_IN
4	4	4	2	-	PC15	I/O	COM	-	TIM15_BKIN	OSC32_OUT
5	5	5	-	1	PF0-OSC_IN	I/O	COM	-	USART2_TX	OSC_IN
6	6	6	-	2	PF1-OSC_OUT	I/O	COM	-	TIM1_BKIN	OSC_OUT
7	7	7	3	3	PF2-NRST	I/O	RST	(1)	TIM14_CH1	-
8	-	-	-	-	PC0	I/O	COM	-	USART2_RX	ADC_IN10, COMP1_INP0 COMP2_INN0, SEG27
9	-	-	-	-	PC1	I/O	COM	-	TIM1_CH1N	ADC_IN11, COMP1_INP1, COMP2_INN1, SEG26
									TIM15_CH1N	
									TIM1_CH2	
									EVENTOUT	
									MCO	
									EVENTOUT	
									SPI1_MISO/I ² S1_MCK	
									USART2_CTS	
									USART3_RTS	
									EVENTOUT	
									SPI1_MOSI/I ² S1_SD	
									USART2_RTS	

Package					Reset	Ports Type	Ports structure	Notes	Pin functions	
LQFP64 R1 /R2	LQFP48 C1	QFN48 C1	QFN32 (5*5) K1	QFN32 (4*4) K2					Alternate functions	Additional functions
									USART3_CTS	
									TIM15_CH1	
10	-	-	-	-	PC2	I/O	COM	-	EVENTOUT	ADC_IN12, COMP1_INP2, COMP2_INN2, SEG25
									SPI2_MISO/I ² S2_MCK	
									USART3_TX	
									USART3_RX	
									TIM15_CH2	
11	-	-	-	-	PC3	I/O	COM	-	EVENTOUT	ADC_IN13, COMP1_INP3, COMP2_INN3, SEG24
									SPI2_MOSI/I ² S2_SD	
									USART3_RX	
									USART3_TX	
12	8	8	4	4	V _{SSA}	G	-	-	Ground	
13	9	9	5	5	V _{CCA}	S	-	-	Analog power supply	
14	10	10	6	6	PA0	I/O	COM	-	USART2_CTS	ADC_IN0, COMP1_INP4, COMP1_INN0, COMP2_INP0, COMP2_INN4, SEG23
									TIM2_CH1_ETR	
									USART4_TX	
									COMP1_OUT	
									SPI2_SCK	
15	11	11	7	7	PA1	I/O	COM	-	EVENTOUT	ADC_IN1, COMP1_INP5, COMP1_INN1, COMP2_INP1, COMP2_INN5, SEG22
									USART2_RTS	
									TIM2_CH2	
									USART4_RX	
									TIM15_CH1N	

Package					Reset	Ports Type	Ports structure	Notes	Pin functions	
LQFP64 R1 /R2	LQFP48 C1	QFN48 C1	QFN32 (5*5) K1	QFN32 (4*4) K2					Alternate functions	Additional functions
									I ² C1_SMBA	
									SPI1_SCK/I ² S1_CK	
									SPI2_MOSI	
16	12	12	8	8	PA2	I/O	COM	-	TIM15_CH1	ADC_IN2, COMP1_INP6, COMP1_INN2, COMP2_INP2, SEG21
									USART2_TX	
									TIM2_CH3	
									COMP2_OUT	
									SPI1_MOSI/I ² S1_SD	
									SPI2_MISO	
17	13	13	9	9	PA3	I/O	COM	-	EVENTOUT	ADC_IN3, COMP1_INP7, COMP1_INN3, COMP2_INP3, SEG20
									TIM15_CH2	
									USART2_RX	
									TIM2_CH4	
									SPI2_MISO	
									SPI2_NSS/I ² S2_WS	
18	-	-	-	-	PF3	I/O	COM_F	-	EVENTOUT	-
									I ² C1_SCL	
									I ² C2_SCL	
19	-	-	-	-	PF4	I/O	COM_F	-	I ² C1_SCL	-
									I ² C2_SCL	
20	14	14	10	10	PA4	I/O	COM	-	EVENTOUT	ADC_IN4, COMP1_INP8, COMP1_INN4, COMP2_INP4,
									SPI1_NSS/I ² S1_WS	
									USART2_CK	

Package					Reset	Ports Type	Ports structure	Notes	Pin functions	
LQFP64 R1 /R2	LQFP48 C1	QFN48 C1	QFN32 (5*5) K1	QFN32 (4*4) K2					Alternate functions	Additional functions
									TIM14_CH1 SPI2_MOSI USART2_TX PVD_OUT	SEG19
21	15	15	11	11	PA5	I/O	COM	-	EVENTOUT SPI1_SCK/I ² S1_CK TIM2_CH1_ETR USART3_TX	ADC_IN5, COMP1_INP9, COMP1_INN5, COMP2_INP5, SEG18, OPA2_OUT
22	16	16	12	12	PA6	I/O	COM	-	EVENTOUT SPI1_MISO/I ² S1_MCK TIM3_CH1 TIM1_BKIN USART3_CTS TIM16_CH1 COMP1_OUT	ADC_IN6, COMP1_INP10, COMP1_INN6, OPA2_INN, SEG17
23	17	17	13	13	PA7	I/O	COM	-	EVENTOUT SPI1_MOSI/I ² S1_SD TIM3_CH2 TIM1_CH1N TIM14_CH1 TIM17_CH1 COMP2_OUT	ADC_IN7, COMP1_INP11, COMP1_INN7, OPA2_INP, SEG16

Package					Reset	Ports Type	Ports structure	Notes	Pin functions	
LQFP64 R1 /R2	LQFP48 C1	QFN48 C1	QFN32 (5*5) K1	QFN32 (4*4) K2					Alternate functions	Additional functions
24	-	-	-	-	PC4	I/O	COM	-	EVENTOUT USART3_TX SPI1_NSS/I ² S1_WS USART1_TX TIM2_CH1_ETR IR_OUT	ADC_IN14, COMP1_INN8, SEG15
25	-	-	-	-	PC5	I/O	COM	-	USART3_RX SPI1_MOSI/I ² S1_SD USART1_RX TIM2_CH2	ADC_IN15, COMP1_INN9, SEG14
26	18	18	14	14	PB0	I/O	COM	-	EVENTOUT TIM3_CH3 TIM1_CH2N USART3_CK COMP1_OUT SPI1_NSS/I ² S1_WS USART3_RX	ADC_IN8, COMP2_INN6, SEG13
27	19	19	15	15	PB1	I/O	COM	-	EVENTOUT TIM14_CH1 TIM3_CH4 TIM1_CH3N USART3_RTS	ADC_IN9, COMP2_INP6, COMP2_INN7, SEG12
28	20	20	-	-	PB2	I/O	COM	-	EVENTOUT	COMP2_INP7,

Package					Reset	Ports Type	Ports structure	Notes	Pin functions	
LQFP64 R1 /R2	LQFP48 C1	QFN48 C1	QFN32 (5*5) K1	QFN32 (4*4) K2					Alternate functions	Additional functions
									SPI2_MISO	COMP2_INN8, SEG11
									USART3_TX	
29	21	21	-	-	PB10	I/O	COM_F	-	I ² C2_SCL	COMP2_INP8, SEG10
									TIM2_CH3	
									USART3_TX	
									SPI2_SCK/I ² S2_CK	
									COMP1_OUT	
									USART2_RTS	
									I ² C1_SCL	
30	22	22	-	-	PB11	I/O	COM_F	-	EVENTOUT	SEG9
									I ² C2_SDA	
									TIM2_CH4	
									USART3_RX	
									COMP2_OUT	
									SPI2_MOSI	
									USART2_CTS	
									I ² C1_SDA	
31	23	23	16	16	V _{SS}	G	-	-	Ground	
32	24	24	17	17	V _{CC}	S	-	-	Digital power supply	
33	25	25	-	18	PB12	I/O	COM	-	EVENTOUT	COMP2_INP9 SEG8
									SPI2_NSS/I ² S2_WS	
									TIM1_BKIN	
									USART3_CK	

Package					Reset	Ports Type	Ports structure	Notes	Pin functions	
LQFP64 R1 /R2	LQFP48 C1	QFN48 C1	QFN32 (5*5) K1	QFN32 (4*4) K2					Alternate functions	Additional functions
									TIM15_BKIN	
34	26	26	-	19	PB13	I/O	COM_F	-	EVENTOUT	COMP2_INP10, SEG7
									SPI2_SCK/I ² S2_CK	
									TIM1_CH1N	
									USART3_CTS	
									I ² C2_SCL	
									MCO	
									TIM15_CH1N	
									I ² C1_SCL	
35	27	27	-	20	PB14	I/O	COM_F	-	EVENTOUT	COMP2_INP11, SEG6
									SPI2_MISO/I ² S2_MCK	
									TIM15_CH1	
									TIM1_CH2N	
									USART3_RTS	
									I ² C2_SDA	
									I ² C1_SDA	
36	28	28	-	-	PB15	I/O	COM	-	EVENTOUT	SEG5
									SPI2_MOSI/I ² S2_SD	
									TIM15_CH2	
									TIM1_CH3N	
									TIM15_CH1N	
37	-	-	-	-	PC6	I/O	COM	-	TIM3_CH1	SEG4
									SPI2_SCK/I ² S2_CK	

Package					Reset	Ports Type	Ports structure	Notes	Pin functions	
LQFP64 R1 /R2	LQFP48 C1	QFN48 C1	QFN32 (5*5) K1	QFN32 (4*4) K2					Alternate functions	Additional functions
									USART4_RX	
									TIM2_CH3	
38	-	-	-	-	PC7	I/O	COM	-	TIM3_CH2	SEG3
									SPI2_MISO/I ² S2_MCK	
									USART4_TX	
									TIM2_CH4	
39	-	-	-	-	PC8	I/O	COM	-	TIM3_CH3	SEG2
									SPI2_MOSI/I ² S2_SD	
									USART4_CTS	
									TIM1_CH1	
40	-	-	-	-	PC9	I/O	COM	-	TIM3_CH4	SEG1
									SPI2_NSS/I ² S2_WS	
									I ² S1_CKIN	
									USART4_RTS	
									TIM1_CH2	
41	29	29	18	21	PA8	I/O	COM	-	EVENTOUT	SEG0, OPA1_OUT
									MCO	
									USART1_CK	
									TIM1_CH1	
									SPI2_NSS	
									USART1_TX	
42	30	30	19	22	PA9	I/O	COM_F	-	EVENTOUT	COM0 OPA1_INP
									TIM15_BKIN	

Package					Reset	Ports Type	Ports structure	Notes	Pin functions	
LQFP64 R1 /R2	LQFP48 C1	QFN48 C1	QFN32 (5*5) K1	QFN32 (4*4) K2					Alternate functions	Additional functions
									USART1_TX	
									TIM1_CH2	
									I ² C1_SCL	
									SPI2_MISO	
									MCO	
									I ² C2_SCL	
43	31	31	20	23	PA10	I/O	COM_F	-	EVENTOUT	COM1 OPA1_INN
									TIM17_BKIN	
									USART1_RX	
									TIM1_CH3	
									I ² C1_SDA	
									SPI2_MOSI	
									I ² C2_SDA	
44	32	32	21	-	PA11	I/O	COM_U	-	EVENTOUT	COM2
									USART1_CTS	
									TIM1_CH4	
									COMP1_OUT	
									SPI1_MISO/I ² S1_MCK	
									TIM1_BKIN2	
45	33	33	22	-	PA12	I/O	COM_U	-	EVENTOUT	COM3
									USART1_RTS	
									TIM1_ETR	
									COMP2_OUT	

Package					Reset	Ports Type	Ports structure	Notes	Pin functions	
LQFP64 R1 /R2	LQFP48 C1	QFN48 C1	QFN32 (5*5) K1	QFN32 (4*4) K2					Alternate functions	Additional functions
									SPI1_MOSI/I ² S1_SD	
									I ² S1_CKIN	
46	34	34	23	24	PA13	I/O	COM	(2)	EVENTOUT	-
									SWDIO	
									IR_OUT	
									USART1_RX	
									PVD_OUT	
47	35	35	24	25	PF5	I/O	COM	-	TIM1_BKIN2	RTC_OUT
48	36	36	-	26	PF6	I/O	COM	-	USART1_CTS	-
49	37	37	25	27	PA14	I/O	COM	(2)	EVENTOUT	-
									SWCLK	
									USART2_TX	
									USART1_TX	
									PVD_OUT	
50	38	38	-	-	PA15	I/O	COM	-	EVENTOUT	-
									SPI1_NSS/I ² S1_WS	
									USART2_RX	
									TIM2_CH1_ETR	
									USART4_RTS	
									USART3_RTS	
51	-	-	-	-	PC10	I/O	COM	-	USART4_TX	COM4/SEG39
									USART3_TX	

Package					Reset	Ports Type	Ports structure	Notes	Pin functions	
LQFP64 R1 /R2	LQFP48 C1	QFN48 C1	QFN32 (5*5) K1	QFN32 (4*4) K2					Alternate functions	Additional functions
									TIM1_CH3	
52	-	-	-	-	PC11	I/O	COM	-	USART4_RX USART3_RX TIM1_CH4	COM5/SEG38
53	-	-	-	-	PC12	I/O	COM	-	USART4_CK USART3_CK TIM14_CH1	COM6/SEG37
54	-	-	-	-	PF7	I/O	COM	-	TIM3_ETR USART3_RTS TIM1_CH1N	COM7/SEG36
55	39	39	-	28	PB3	I/O	COM	-	EVENTOUT SPI1_SCK/I ² S1_CK TIM2_CH2 USART1_RTS TIM1_CH2	COMP2_INN9 SEG35/VLCDH
56	40	40	26	29	PB4	I/O	COM	-	EVENTOUT SPI1_MISO/I ² S1_MCK TIM3_CH1 USART1_CTS USART1_CK TIM1_CH2N TIM17_BKIN	COMP1_INP12 COMP2_INP12 SEG34/VLCD3
57	41	41	27	30	PB5	I/O	COM	-	SPI1_MOSI/I ² S1_SD	COMP1_INP13

Package					Reset	Ports Type	Ports structure	Notes	Pin functions	
LQFP64 R1 /R2	LQFP48 C1	QFN48 C1	QFN32 (5*5) K1	QFN32 (4*4) K2					Alternate functions	Additional functions
									TIM3_CH2	SEG33/VLCD2
									TIM16_BKIN	
									I ² C1_SMBA	
									USART1_CK	
									COMP2_OUT	
									USART1_RTS	
									USART1_TX	
									TIM1_CH3N	
58	42	42	28	31	PB6	I/O	COM_F	-	EVENTOUT	COMP1_INP14, COMP2_INP14 SEG32/VLCD1
									USART1_TX	
									I ² C1_SCL	
									TIM16_CH1N	
									SPI2_MISO	
									USART3_CTS	
									TIM1_CH3	
									I ² C2_SCL	
59	43	43	29	32	PB7	I/O	COM_F	-	EVENTOUT	PVD_IN, COMP2_INP15 SEG31
									USART1_RX	
									I ² C1_SDA	
									TIM17_CH1N	
									USART4_CTS	
									SPI2_MOSI	
									I ² C2_SDA	

Package					Reset	Ports Type	Ports structure	Notes	Pin functions	
LQFP64 R1 /R2	LQFP48 C1	QFN48 C1	QFN32 (5*5) K1	QFN32 (4*4) K2					Alternate functions	Additional functions
60	44	44	30	-	PF8/BOOT	I/O	COM	(3)	TIM1_CH1 -	SEG30
61	45	45	31	-	PB8	I/O	COM_F	-	EVENTOUT I ² C1_SCL I ² C2_SCL TIM16_CH1 SPI2_SCK USART1_TX USART3_TX TIM15_BKIN TIM1_CH1N	SEG29
62	46	46	32	-	PB9	I/O	COM_F	-	EVENTOUT IR_OUT I ² C1_SDA TIM17_CH1 SPI2_NSS/I ² S2_WS USART1_RX USART3_RX I ² C2_SDA	SEG28
63	47	47	-	-	V _{SS}	G	-	-	Ground	
64	48	48	-	-	V _{CC}	S	-	-	Digital power supply	

1. Configure by option bytes to choose PF2 or NRST.

2. After reset, PA13 and PA14 are configured as SWDIO and SWCLK AF functions, the former has an internal pull-up resistor and the latter has an internal pull-down resistor activated.
3. BOOT0 defaults to digital input mode and pull-down is enable.

Puya Confidential

3.1. PortA alternate function mapping

Table 3-3 PortA alternate function mapping

PortA	AF0	AF1	AF2	AF3	AF4	AF5	AF6	AF7	AF8	AF9	AF10	AF11	AF12	AF13	AF14	AF15
PA0	-	USART2_CTS	TIM2_CH1_ETR	-	USART4_TX	-	-	COMP1_OUT	SPI2_SCK	-	-	-	-	-	-	-
PA1	EVENTOUT	USART2_RTS	TIM2_CH2	-	USART4_RX	TIM15_CH1N	I ² C1_SMBA	-	SPI1_SCK/ I ² S1_CK	SPI2_MOSI	-	-	-	-	-	-
PA2	TIM15_CH1	USART2_TX	TIM2_CH3	-	-	-	-	COM2_OUT	SPI1_MOSI/ I ² S1_SD	SPI2_MISO	-	-	-	-	-	-
PA3	TIM15_CH2	USART2_RX	TIM2_CH4	-	-	-	-	EVENTOUT	SPI2_MSIO	SPI2_NSS/ I ² S2_WS	-	-	-	-	-	-
PA4	SPI1_NSS/ I ² S1_WS	USART2_CK	-	-	TIM14_CH1	-	-	EVENTOUT	SPI2_MOSI	USART2_TX	-	-	PVD_OUT	-	-	-
PA5	SPI1_SCK/ I ² S1_CK	-	TIM2_CH1_ETR	-	-	-	-	EVENTOUT	-	-	USART3_TX	-	-	-	-	-
PA6	SPI1_MISO/ I ² S1_MCK	TIM3_CH1	TIM1_BKIN	-	USART3_CTS	TIM16_CH1	EVENTOUT	COMP1_OUT	-	-	-	-	-	-	-	-
PA7	SPI1_MOSI/ I ² S1_SD	TIM3_CH2	TIM1_CH1N	-	TIM14_CH1	TIM17_CH1	EVENTOUT	COMP2_OUT	-	-	-	-	-	-	-	-
PA8	MCO	USART1_CK	TIM1_CH1	EVENTOUT	-	-	-	-	SPI2_NSS	-	USART1_TX	-	-	-	-	-
PA9	TIM15_BKIN	USART1_TX	TIM1_CH2	-	-	-	I ² C1_SCL	EVENTOUT	SPI2_MISO	MCO	-	-	-	I ² C2_SCL	-	-
PA10	TIM17_BKIN	USART1_RX	TIM1_CH3	-	-	-	I ² C1_SDA	EVENTOUT	SPI2_MOSI	-	-	-	-	I ² C2SDA	-	-
PA11	EVENTOUT	USART1_CTS	TIM1_CH4	-	-	-	-	COMP1_OUT	SPI1_MISO/ I ² S1_MCK	-	-	TIM1_BKIN2	-	-	-	-
PA12	EVENTOUT	USART1_RTS	TIM1_ETR	-	-	-	-	COMP2_OUT	SPI1_MOSI/ I ² S1_SD	I ² S1_CKIN	-	-	-	-	-	-
PA13	SWDIO	IROUT	-	-	-	-	-	EVENTOUT	-	USART1_RX	-	-	PVD_OUT	-	-	-
PA14	SWCLK	USART2_TX	-	-	-	-	-	EVENTOUT	-	USART1_TX	-	-	PVD_OUT	-	-	-
PA15	SPI1_NSS/ I ² S1_WS	USART2_RX	TIM2_CH1_ETR	EVENTOUT	USART4_RTS	-	-	EVENTOUT	-	-	USART3_RTS_DE_CK	-	-	-	-	-

3.2. PortB alternate function mapping

Table 3-4 Port B alternate function mapping

Port B	AF0	AF1	AF2	AF3	AF4	AF5	AF6	AF7	AF8	AF9	AF10	AF11	AF12	AF13	AF14	AF15
PB0	EVENTOUT	TIM3_CH3	TIM1_CH2N	-	USART3_CK	-	-	COMP1_OUT	SPI1_NSS/I ² S1_WS	-	USART3_RX	-	-	-	-	-
PB1	TIM14_CH1	TIM3_CH4	TIM1_CH3N	-	USART3_RTS	-	-	EVENTOUT	-	-	-	-	-	-	-	-
PB2	-	-	-	-	-	-	-	EVENTOUT	SPI2_MISO	-	USART3_TX	-	-	-	-	-
PB3	SPI1_SCK/I ² S1_CK	EVENTOUT	TIM2_CH2	-	USART1_RTS	-	-	EVENTOUT	-	-	-	TIM1_CH2	-	-	-	-
PB4	SPI1_MISO/I ² S1_MCK	TIM3_CH1	EVENTOUT	-	USART1_CTS	TIM17_BKIN	-	-	-	-	-	TIM1_CH2N	-	USART1_CK	-	-
PB5	SPI1_MOSI/I ² S1_SD	TIM3_CH2	TIM16_BKIN	I ² C1_SMBA	USART1_CK	-	-	COM2_OUT	-	USART1_RTS	-	TIM1_CH3N	-	USART1_TX	-	-
PB6	USART1_TX	I ² C1_SCL	TIM16_CH1N	-	-	-	-	EVENTOUT	SPI2_MISO	-	USART3_CTS	TIM1_CH3	-	I ² C2_SCL	-	-
PB7	USART1_RX	I ² C1_SDA	TIM17_CH1N	-	USART4_CTS	-	-	EVENTOUT	SPI2_MOSI	-	-	TIM1_CH1	-	I ² C2_SDA	-	-
PB8	-	I ² C1_SCL	TIM16_CH1	-	-	-	-	EVENTOUT	SPI2_SCK	USART1_TX	USART3_TX	TIM15_BKIN	-	I ² C2_SCL	TIM1_CH1N	-
PB9	IR_OUT	I ² C1_SDA	TIM17_CH1	EVENTOUT	-	SPI2_NSS/I ² S2_WS	-	-	-	USART1_RX	USART3_RX	-	-	I ² C2_SDA	-	-
PB10	-	I ² C2_SCL	TIM2_CH3	-	USART3_TX	SPI2_SCK/I ² S2_CK	-	COMP1_OUT	-	USART2_RTS	-	-	-	I ² C1_SCL	-	-
PB11	EVENTOUT	I ² C2_SDA	TIM2_CH4	-	USART3_RX	-	-	COMP2_OUT	SPI2_MOSI	USART2_CTS	-	-	-	I ² C1_SDA	-	-
PB12	SPI2_NSS/I ² S2_WS	EVENTOUT	TIM1_BKIN	-	USART3_CK	TIM15_BKIN	-	-	-	-	-	-	-	-	-	-
PB13	SPI2_SCK/I ² S2_CK	-	TIM1_CH1N	-	USART3_CTS	I ² C2_SCL	-	EVENTOUT	-	MCO	-	TIM15_CH1N	-	I ² C1_SCL	-	-
PB14	SPI2_MISO/I ² S2_MCK	TIM15_CH1	TIM1_CH2N	-	USART3_RTS	I ² C2_SDA	-	EVENTOUT	-	-	-	TIM15_CH1	-	I ² C1_SDA	-	-
PB15	SPI2_MOSI/I ² S2_SD	TIM15_CH2	TIM1_CH3N	TIM15_CH1N	-	-	-	EVENTOUT	-	-	-	-	-	-	-	-

3.3. PortC alternate function mapping

Table 3-5 PortC alternate function mapping

PortC	AF0	AF1	AF2	AF3	AF4	AF5	AF6	AF7	AF8	AF9	AF10	AF11	AF12	AF13	AF14	AF15
PC0	EVENTOUT	-	-	-	-	-	-	-	SPI1_MISO/I ² S1_MCK	USART2_CTS	USART3_RTS	-	-	-	-	-
PC1	EVENTOUT	-	-	-	-	-	-	-	SPI1_MOSI/I ² S1_SD	USART2_RTS	USART3_CTS	TIM15_CH1	-	-	-	-
PC2	EVENTOUT	SPI2_MISO/I ² S2_MCK	-	-	-	-	-	-	-	USART3_TX	USART3_RX	TIM15_CH2	-	-	-	-
PC3	EVENTOUT	SPI2_MOSI/I ² S2_SD	-	-	-	-	-	-	-	USART3_RX	USART3_TX	-	-	-	-	-
PC4	EVENTOUT	USART3_TX	-	-	-	-	-	-	SPI1_NSS/I ² S1_WS	USART1_TX	-	TIM2_CH1_ETR	IR_OUT	-	-	-

PortC	AF0	AF1	AF2	AF3	AF4	AF5	AF6	AF7	AF8	AF9	AF10	AF11	AF12	AF13	AF14	AF15
PC5	-	USART3_RX	-	-	-	-	-	-	SPI1_MOSI/I ² S1_SD	USART1_RX	-	TIM2_CH2	-	-	-	-
PC6	TIM3_CH1	-	-	-	-	-	-	-	SPI2_SCK/I ² S2_CK	-	USART4_RXD	TIM2_CH3	-	-	-	-
PC7	TIM3_CH2	-	-	-	-	-	-	-	SPI2_MISO/I ² S2_MCK	-	USART4_TX	TIM2_CH4	-	-	-	-
PC8	TIM3_CH3	-	-	-	-	-	-	-	SPI2_MOSI/I ² S2_SD	-	USART4_CTS	TIM1_CH1	-	-	-	-
PC9	TIM3_CH4	-	-	-	-	-	-	-	SPI2_NSS/I ² S2_WS	I ² S1_CKIN	USART4_RTS	TIM1_CH2	-	-	-	-
PC10	USART4_TX	USART3_TX	-	-	-	-	-	-	-	-	-	TIM1_CH3	-	-	-	-
PC11	USART4_RX	USART3_RX	-	-	-	-	-	-	-	-	-	TIM1_CH4	-	-	-	-
PC12	USART4_CK	USART3_CK	-	-	-	-	-	-	-	-	-	TIM14_CH1	-	-	-	-
PC13	-	-	-	-	-	-	-	-	SPI1_SCK/I ² S1_CK	-	-	TIM1_BKIN	-	-	-	-
PC14	-	-	-	-	-	-	-	-	-	-	-	TIM1_BKIN2	-	-	-	-
PC15	-	-	-	-	-	-	-	-	-	-	-	TIM15_BKIN	-	-	-	-

3.4. PortF alternate function mapping

Table 3-7 PortF alternate function mapping

PortF	AF0	AF1	AF2	AF3	AF4	AF5	AF6	AF7	AF8	AF9	AF10	AF11	AF12	AF13	AF14	AF15
PF0	-	-	-	-	-	-	-	-	-	USART2_TX	-	TIM14_CH1	-	TIM1_BKIN	-	-
PF1	-	-	-	-	-	-	-	-	-	USART2_RX	-	TIM15_CH1N	-	TIM1_CH1N	-	-
PF2	EVEN-TOUT	-	-	-	-	-	-	-	MCO	-	-	-	-	TIM1_CH2	-	-
PF3	EVEN-TOUT	-	-	-	-	-	I ² C1_SCL	-	-	-	-	-	-	I ² C2_SCL	-	-
PF4	-	-	-	-	-	-	I ² C1_SDA	-	-	-	-	-	-	I ² C2_SDA	-	-
PF5	-	-	TIM1_BKIN2	-	-	-	-	-	-	-	-	-	-	-	-	-
PF6	-	-	-	-	USART1_CTS	-	-	-	-	-	-	-	-	-	-	-
PF7	TIM3_ETR	USART3_RTS	-	-	-	-	-	-	-	-	-	TIM1_CH1N	-	-	-	-
PF8	-	-	-	-	-	-	-	-	-	-	-	-	-	-	-	-
PF9	-	-	-	-	-	-	-	-	-	-	-	-	-	-	-	-

4. Memory Map

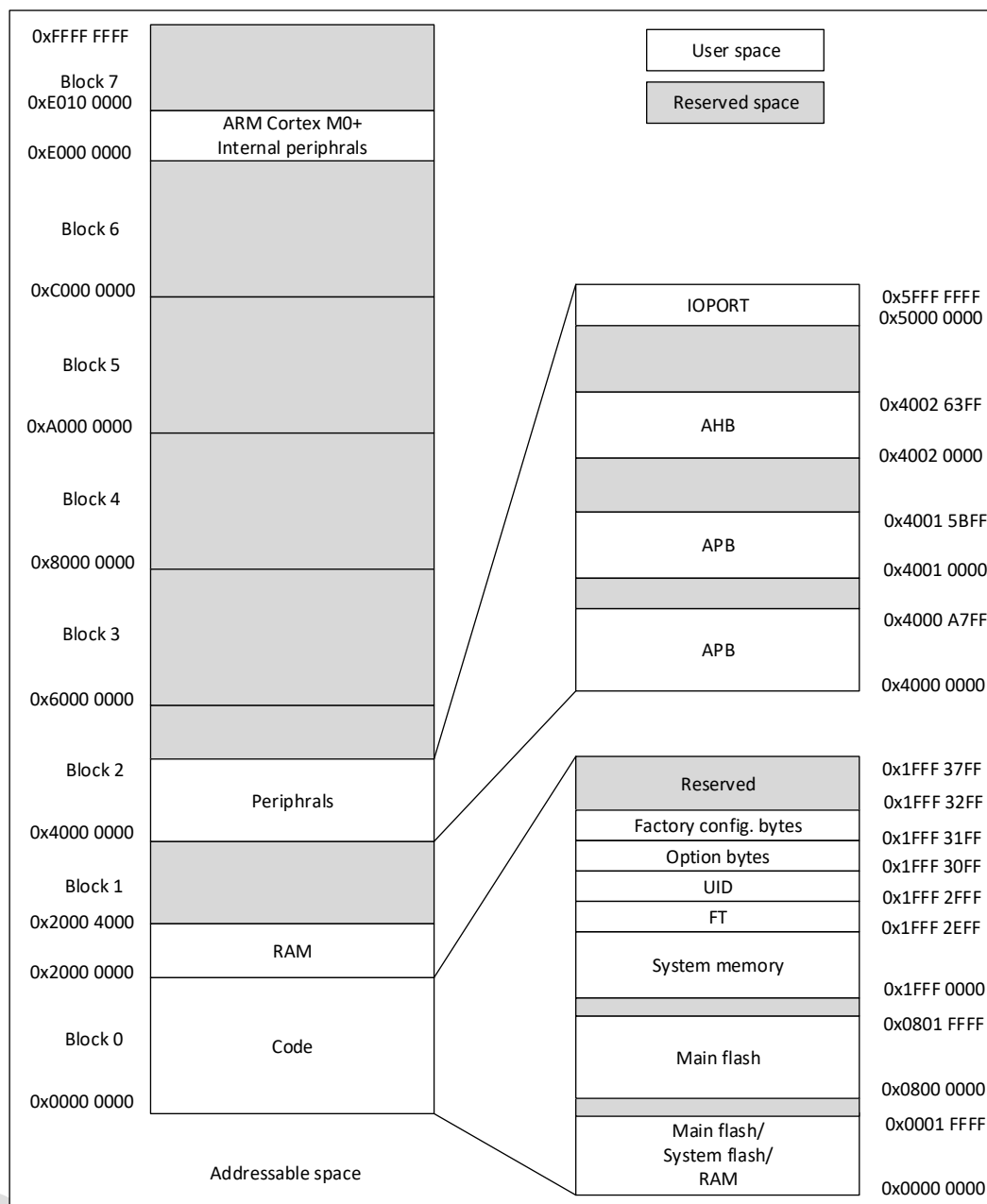

Figure 4-1 Memory map

Table 4-1 Memory boundary address

Type	Boundary Address	Size	Memory Area	Description
SRAM	0x2000 4000-0x3FFF FFFF	-	Reserved	-
	0x2000 0000-0x2000 3FFF	16 KBytes	SRAM	If the hardware power-up configuration of the SRAM is 16 KBytes, then the SRAM address space is 0x2000 0000-0x2000 3FFF
Code	0x1FFF 3400-0x1FFF FFFF	-	Reserved	-
	0x1FFF 3300-0x1FFF 33FF	256 Bytes	FT infor1 bytes	Flash Verify Value, Analog 和 Flash Trimming, Debug ID.
	0x1FFF 3200-0x1FFF 32FF	256 Bytes	FT infor0 bytes	Normal TS DATA,

Type	Boundary Address	Size	Memory Area	Description
				High TS DATA, HSI Re-Trim data, Flash/sram size configuration.
	0x1FFF 3100-0x1FFF 31FF	256 Bytes	Option bytes	option bytes information, IP enable ⁽¹⁾
	0x1FFF 3000-0x1FFF 30FF	256 Bytes	UID bytes	Unique ID
	0x1FFF 0000-0x1FFF 2FFF	12 Kbytes	System memory	boot loader
	0x0802 0000-0x1FFE FFFF	-	Reserved	-
	0x0800 0000-0x0801 FFFF	128 Kbytes	Main flash memory	-
	0x0002 0000-0x07FF FFFF	-	Reserved	-
	0x0000 0000-0x0001 FFFF	128 Kbytes	Selected based on Boot configuration, 1) Main flash memory 2) System memory 3) SRAM	

1. Except the above address, other is marked as reserved, which cannot be written, read as 0, and a response error is generated.

Table 4-2 Peripheral register boundary address⁽¹⁾

Bus	Boundary Address	Size	Peripheral
	0xE000 000-0xE00F FFFF	1 MB	M0+
IOPORT	0x5000 1800 - 0x5FFF FFFF	-	Reserved
	0x5000 1400 - 0x5000 17FF	1 KB	GPIOF
	0x5000 1000 - 0x5000 13FF	-	Reserved
	0x5000 0C00 - 0x5000 0FFF	-	Reserved
	0x5000 0800 - 0x5000 0BFF	1 KB	GPIOC
	0x5000 0400 - 0x5000 07FF	1 KB	GPIOB
	0x5000 0000 - 0x5000 03FF	1 KB	GPIOA
AHB	0x4002 4000 - 0x4FFF FFFF	-	Reserved
	0x4002 3C00 - 0x4002 3FFF	-	Reserved
	0x4002 3800 - 0x4002 3BFF	1 KB	DIV
	0x4002 3400 - 0x4002 37FF	-	Reserved
	0x4002 3000 - 0x4002 33FF	1 KB	CRC
	0x4002 2400 - 0x4002 2FFF	-	Reserved
	0x4002 2000 - 0x4002 23FF	1 KB	FLASH
	0x4002 1C00 - 0x4002 1FFF	-	Reserved
	0x4002 1800 - 0x4002 1BFF	1 KB	EXTI
	0x4002 1400 - 0x4002 17FF	-	Reserved
	0x4002 1000 - 0x4002 13FF	1 KB	RCC ⁽²⁾
	0x4002 0400 - 0x4002 0FFF	-	Reserved
	0x4002 0000 - 0x4002 03FF	1 KB	DMA
APB	0x4001 5C00 - 0x4001 FFFF	-	Reserved
	0x4001 5800 - 0x4001 5BFF	1 KB	DBG
	0x4001 4C00 - 0x4001 57FF	-	Reserved
	0x4001 4800 - 0x4001 4BFF	1 KB	TIM17

Bus	Boundary Address	Size	Peripheral
	0x4001 4400 - 0x4001 47FF	1 KB	TIM16
	0x4001 4000 - 0x4001 43FF	1 KB	TIM15
	0x4001 3C00 - 0x4001 3FFF	-	Reserved
	0x4001 3800 - 0x4001 3BFF	1 KB	USART1
	0x4001 3400 - 0x4001 37FF	-	Reserved
	0x4001 3000 - 0x4001 33FF	1 KB	SPI1/I2S1
	0x4001 2C00 - 0x4001 2FFF	1 KB	TIM1
	0x4001 2800 - 0x4001 2BFF	-	Reserved
	0x4001 2400 - 0x4001 27FF	1 KB	ADC
	0x4001 0400 - 0x4001 23FF	-	Reserved
	0x4001 0300 - 0x4001 03FF	1 KB	OPA
	0x4001 0200 - 0x4001 02FF		COMP
	0x4001 0000 - 0x4001 01FF		SYSCFG
	0x4000 8000- 0x4000 FFFF	-	Reserved
	0x4000 7C00 - 0x4000 7FFF	1 KB	LPTIM1
	0x4000 7800 - 0x4000 7BFF	-	Reserved
	0x4000 7400 - 0x4000 77FF	-	Reserved
	0x4000 7000 - 0x4000 73FF	1 KB	PWR ⁽³⁾
	0x4000 6C00 - 0x4000 6FFF	-	Reserved
	0x4000 6800 - 0x4000 6BFF	-	Reserved
	0x4000 6400 - 0x4000 67FF	-	Reserved
	0x4000 6000 - 0x4000 63FF	-	Reserved
	0x4000 5C00 - 0x4000 5FFF	-	Reserved
	0x4000 5800 - 0x4000 5BFF	1 KB	I ² C2
	0x4000 5400 - 0x4000 57FF	1 KB	I ² C1
	0x4000 5000 - 0x4000 53FF	-	Reserved
	0x4000 4C00 - 0x4000 4FFF	1 KB	USART4
	0x4000 4800 - 0x4000 4BFF	1 KB	USART3
	0x4000 4400 - 0x4000 47FF	1 KB	USART2
	0x4000 3C00 - 0x4000 43FF	-	Reserved
	0x4000 3800 - 0x4000 3BFF	1 KB	SPI2/I2S2
	0x4000 3400 - 0x4000 37FF	-	Reserved
	0x4000 3000 - 0x4000 33FF	1 KB	IWDG
	0x4000 2C00 - 0x4000 2FFF	1 KB	WWDG
	0x4000 2800 - 0x4000 2BFF	1 KB	RTC
	0x4000 2400 - 0x4000 27FF	1 KB	LCD
	0x4000 2000 - 0x4000 23FF	1 KB	TIM14
	0x4000 1800 - 0x4000 1FFF	-	Reserved
	0x4000 1400 - 0x4000 17FF	1 KB	TIM7
	0x4000 1000 - 0x4000 13FF	1 KB	TIM6

Bus	Boundary Address	Size	Peripheral
	0x4000 0800 - 0x4000 0FFF	-	Reserved
	0x4000 0400 - 0x4000 07FF	1 KB	TIM3
	0x4000 0000 - 0x4000 03FF	1 KB	TIM2

1. In the above table, the reserved address cannot be written, read back is 0, and a hardfault is generated
2. Not only supports 32 bits word access, but also supports halfword and byte access.
3. Not only supports 32 bits word access, but also supports halfword access.

Puya Confidential

5. Electrical Characteristics

5.1. Parameter conditions

Unless otherwise specified, all voltages are referenced to V_{SS} .

5.1.1. Minimum and maximum values

Unless otherwise specified, the minimum and maximum values are guaranteed in the worst conditions of ambient temperature, supply voltage and frequencies by tests in production on 100% of the devices with an ambient temperature at $T_A = 25^\circ\text{C}$ and $T_A = T_{A(\text{max})}$ (given by the selected temperature range).

Data based on electrical characterization results, design simulations and/or technology characteristics are indicated in the table footnotes and are not tested in production. Based on characterization, the minimum and maximum values refer to sample tests and represent the mean value plus or minus three times the standard deviation.

5.1.2. Typical values

Unless otherwise specified, typical data is based on $T_A = 25^\circ\text{C}$ and $V_{CC} = 3.3\text{V}$. They are given only as design guidelines and are not tested.

Typical ADC accuracy values are determined by characterization of a batch of samples from a standard diffusion lot over the full temperature range, where 95% of the devices have an error less than equal to the value indicated.

5.2. Absolute maximum ratings

Stresses above the absolute maximum ratings listed in following tables may cause permanent damage to the device. These are stress ratings only and functional operation of the device at these conditions is not implied. Exposure to maximum rating conditions for extended periods may affect device reliability.

Table 5-1 Voltage characteristics ⁽¹⁾

Symbol	Ratings	Minimum	Maximum	Unit
V_{CC}	External mains power supply	-0.3	6.25	V
V_{IN}	Input voltage of other pins	-0.3	$V_{CC} + 0.3$	V

1. Power supply V_{CC} and ground V_{SS} pins must always be connected to the external power supply within the allowable range.

Table 5-2 Current characteristics

Symbol	Describe	Maximum	Unit
I_{VCC}	Flowing into V_{CC} pin (supply current) ⁽¹⁾	300	mA
I_{VSS}	Total current flowing out of V_{SS} pin (outflow current) ⁽¹⁾	300	
$I_{IO(\text{PIN})}$	Output sink current of COM IO ⁽²⁾	20	
	Source current for all IOs	-20	

1. Power supply V_{CC} and ground V_{SS} pins must always be connected to the external power supply within the allowable range.
2. These I/O types refer to the terms and symbols defined by pins.

Table 5-3 Thermal characteristics

Symbol	Describe	Condition	Value	Unit
T_{STG}	Storage temperature range		-65 to +150	$^\circ\text{C}$
T_O	Range of operating temperature	x6 version	-40 to +85	$^\circ\text{C}$
		x7 version	-40 to +105	

5.3. Operating conditions

5.3.1. General operating conditions

Table 5-4 General operating conditions

Symbol	Parameter	Condition	Minimum	Maximum	Unit
f _{HCLK}	Internal AHB clock frequency	-	0	72	MHz
f _{PCLK}	Internal APB Clock frequency	-	0	72	MHz
V _{CC}	Standard operating voltage	-	1.7	5.5	V
V _{CCA}	Operating voltage of analog circuit	Must be the same as V _{CC}	1.7	5.5	V
V _{IN}	I/O input voltage	-	-0.3	V _{CC} + 0.3	V
T _A	Ambient temperature	x6 version	-40	85	°C
		x7 version	-40	105	
T _J	Junction temperature	x6 version	-40	90	°C
		x7 version	-40	110	

- It is recommended that the same power supply be used for both V_{CC} and V_{CCA}, and that a maximum of 300 mV be allowed between V_{CC} and V_{CCA} during power-up and normal operation.

5.3.2. Operating conditions at power-up / power-down

Table 5-5 Operating conditions at power-up / power-down

Symbol	Parameter	Condition	Minimum	Maximum	Unit
t _{vcc}	V _{CC} rise time rate	-	0	∞	us/V
	V _{CC} fall time rate	-	20	∞	

5.3.3. Embedded reset and LVD module features

Table 5-6 Embedded reset module features

Symbol	Parameter	Condition	Minimum	Typical	Maximum	Unit
V _{PVD}	Programmable voltage detector level selection	PLS[2:0]=000 (Rising edge)	1.7	1.8	1.9	V
		PLS[2:0]=000 (Falling edge)	1.6	1.7	1.8	V
		PLS[2:0]=001 (Rising edge)	1.9	2	2.1	V
		PLS[2:0]=001 (Falling edge)	1.8	1.9	2	V
		PLS[2:0]=010 (Rising edge)	2.1	2.2	2.3	V
		PLS[2:0]=010 (Falling edge)	2	2.1	2.2	V
		PLS[2:0]=011 (Rising edge)	2.3	2.4	2.5	V
		PLS[2:0]=011 (Falling edge)	2.2	2.3	2.4	V
		PLS[2:0]=100 (Rising edge)	2.5	2.6	2.7	V
		PLS[2:0]=100 (Falling edge)	2.4	2.5	2.6	V
		PLS[2:0]=101 (Rising edge)	2.7	2.8	2.9	V
		PLS[2:0]=101 (Falling edge)	2.6	2.7	2.8	V
		PLS[2:0]=110 (Rising edge)	2.9	3	3.1	V
		PLS[2:0]=110 (Falling edge)	2.8	2.9	3	V
		PLS[2:0]=111 (Rising edge)	3.1	3.2	3.3	V
PLS[2:0]=111 (Falling edge)	3	3.1	3.2	V		
V _{PVDhyst} ⁽¹⁾	PVD hysteresis	-	-	100	-	mV
V _{POR/PDR}	Power-on/power-off reset threshold	Rising edge	1.5	1.6	1.7	V
		Falling edge	1.45	1.55	1.65	V
V _{PDRhyst} ⁽¹⁾	PDR hysteresis	-	-	20	-	mV
V _{BOR}	BOR Indicates the threshold voltage	BOR_LEV[2:0]=000 (Rising edge)	1.7	1.8	1.9	V

Symbol	Parameter	Condition	Minimum	Typical	Maximum	Unit
		BOR_LEV[2:0]=000 (Falling edge)	1.6	1.7	1.8	V
		BOR_LEV[2:0]=001 (Rising edge)	1.9	2	2.1	V
		BOR_LEV[2:0]=001 (Falling edge)	1.8	1.9	2	V
		BOR_LEV[2:0]=010 (Rising edge)	2.1	2.2	2.3	V
		BOR_LEV[2:0]=010 (Falling edge)	2	2.1	2.2	V
		BOR_LEV[2:0]=011 (Rising edge)	2.3	2.4	2.5	V
		BOR_LEV[2:0]=011 (Falling edge)	2.2	2.3	2.4	V
		BOR_LEV[2:0]=100 (Rising edge)	2.5	2.6	2.7	V
		BOR_LEV[2:0]=100 (Falling edge)	2.4	2.5	2.6	V
		BOR_LEV[2:0]=101 (Rising edge)	2.7	2.8	2.9	V
		BOR_LEV[2:0]=101 (Falling edge)	2.6	2.7	2.8	V
		BOR_LEV[2:0]=110 (Rising edge)	2.9	3	3.1	V
		BOR_LEV[2:0]=110 (Falling edge)	2.8	2.9	3	V
		BOR_LEV[2:0]=111 (Rising edge)	3.1	3.2	3.3	V
		BOR_LEV[2:0]=111 (Falling edge)	3	3.1	3.2	V
V _{BOR_hyst}	BOR hysteresis voltage	-	-	100	-	mV

1. Guaranteed by design, not tested in production..

5.3.4. Operating current characteristics

Table 5-7 Operating mode current

Symbol	Condition						Typical ⁽¹⁾	Maximum ⁽¹⁾		Unit
	System clock	Frequency	Code	Run	Peripheral clock	FLASH sleep		T _A =85 °C	T _A =105 °C	
I _{DD} (run)	PLL	72 MHz	While ⁽¹⁾	Flash	ON	DISA-BLE	8.37	12.70	-	mA
					OFF	DISA-BLE	4.60	7.80	-	
		48 MHz			ON	DISA-BLE	6.54	9.73	-	
					OFF	DISA-BLE	4.01	6.46	-	
	HSI	24 MHz			ON	DISA-BLE	3.82	6.57	-	
					OFF	DISA-BLE	2.60	5.07	-	
		16 MHz			ON	DISA-BLE	2.78	4.94	-	
					OFF	DISA-BLE	1.90	2.75	-	
	8 MHz	ON	DISA-BLE	1.80	3.40	-				

Symbol	Condition						Typical ⁽¹⁾	Maximum ⁽¹⁾		Unit	
	System clock	Frequency	Code	Run	Peripheral clock	FLASH sleep		T _A =85 °C	T _A =105 °C		
		4 MHz			OFF	DISA-BLE	1.21	2.73	-	uA	
					ON	DISA-BLE	1.04	2.22	-		
					OFF	DISA-BLE	0.87	1.34	-		
	LSI	32.768 kHz				ON	DISA-BLE	350.2	824.5		-
						OFF	DISA-BLE	293.2	770.5		-
						ON	ENA-BLE	276.7	720.6		-
						OFF	ENA-BLE	224.6	663.2		-

1. Data is based on assessment results and is not tested in production.

Table 5-8 Sleep mode current

Symbol	Condition				Typical ⁽¹⁾	Maximum ⁽¹⁾		Unit	
	System clock	Frequency	Peripheral clock	FLASH sleep		T _A =85 °C	T _A =105 °C		
I _{DD} (sleep)	PLL	72 MHz	ON	DISABLE	6.16	8.36	-	mA	
			OFF	DISABLE	2.13	3.14	-		
		48 MHz	ON	DISABLE	4.57	6.34	-		
			OFF	DISABLE	1.82	2.73	-		
	HSI	24 MHz	ON	DISABLE	2.12	3.21	-		
			OFF	DISABLE	0.89	1.54	-		
		16 MHz	ON	DISABLE	1.56	2.75	-		
			OFF	DISABLE	0.71	1.53	-		
		8 MHz	ON	DISABLE	1.01	1.73	-		
			OFF	DISABLE	0.53	1.01	-		
		4 MHz	ON	DISABLE	0.74	1.40	-		
			OFF	DISABLE	0.46	0.91	-		
	LSI	32.768 KHz	ON	DISABLE	349.4	824.5	-		uA
			OFF	DISABLE	292.5	770.5	-		
32.768 KHz		ON	ENABLE	278.4	720.6	-			
		OFF	ENABLE	224.4	663.2	-			

1. Data is based on assessment results and is not tested in production.

Table 5-9 Stop mode current

Symbol	Condition					Typical ⁽¹⁾	Maximum ⁽¹⁾		unit	
	V _{CC}	V _{DD}	MR/LPR	LSI	Peripheral clock		T _A =85 °C	T _A =105 °C		
I _{DD} (stop)	1.7 to 5.5 V	1.2 V	MR	-	-	-	90.30	245.40	-	uA
		1.2 V	LPR	ON	RTC+IWDG+LPTIM	6.60	104.90	-		
					IWDG	6.70	104.80	-		
					LPTIM	6.70	104.60	-		
					RTC	6.60	104.60	-		
		1.0 V	LPR	OFF	No	6.50	104.30	-		
					ON	RTC+IWDG+LPTIM	5.80	81.70	-	
						IWDG	5.80	81.70	-	
						LPTIM	5.70	81.60	-	

Symbol	Condition					Typical (1)	Maximum (1)		unit
	V _{CC}	V _{DD}	MR/LPR	LSI	Peripheral clock		T _A =85 °C	T _A =105 °C	
					RTC	5.70	81.60	-	
				OFF	No	5.50	81.40	-	

1. Data is based on assessment results and is not tested in production.

5.3.5. Wake-up time for low power mode

Table 5-10 Low power mode wake-up time

Symbol	Parameters(1)		Condition	Typical (2)	Maximum	Unit	
t _{WUSLEEP}	Wake-up from sleep mode		-	7	-	CPU Cycles	
t _{WUSTOP}	Wake-up from stop mode	Powered by MR	Execute program in Flash, HSI (24 MHz) as system clock	3.5	-	US	
		Powered by LPR	Execute program in Flash, HSI as system clock	V _{DD} =1.2 V	7		-
				V _{DD} =1.0 V	7		-

- The wake-up time is measured from the wake-up time until the first instruction is read by the user program.
- Data is based on assessment results and is not tested in production.

5.3.6. External clock source characteristics

5.3.6.1. External high-speed clock

In bypass mode of HSE (the HSEBYP of RCC_CR is set), when the high-speed start-up circuit in the chip stops working, the corresponding I/O is used as a standard GPIO.

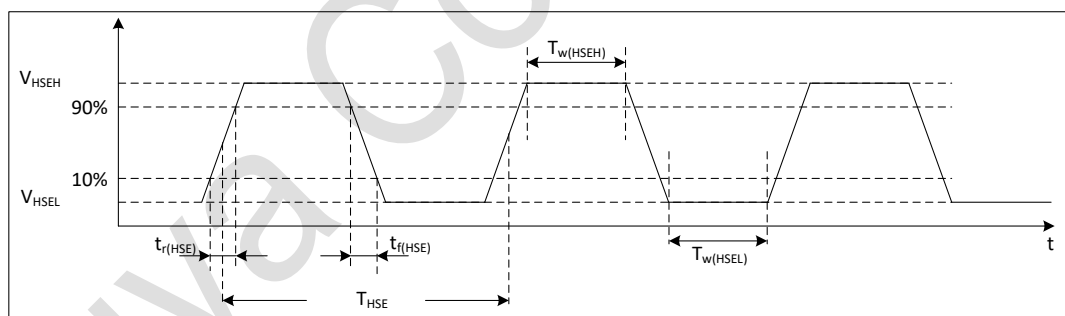

Figure 5-1 External high-speed clock timing diagram

Table 5-11 External high-speed clock features

Symbol	Parameters(1)	Minimum	Typical	Maximum	Unit
f _{HSE_ext}	User external clock source frequency	4	8	32	MHz
V _{HSEH}	Input pin high level voltage	0.7 V _{CC}	-	V _{CC}	V
V _{HSEL}	Input pin low level voltage	V _{SS}	-	0.3 V _{CC}	
t _{w(HSEH)} t _{w(HSEL)}	Enter high or low time	15	-	-	ns
t _{r(HSE)} t _{f(HSE)}	Enter the rise/fall time	-	-	20	ns

1. Guaranteed by design, not tested in production.

5.3.6.2. External low-speed clock

In the bypass mode of LSE (the LSE BYP of RCC_BDCR is set), the low-speed start-up circuit in the chip stops working, and the corresponding I/O is used as a standard GPIO.

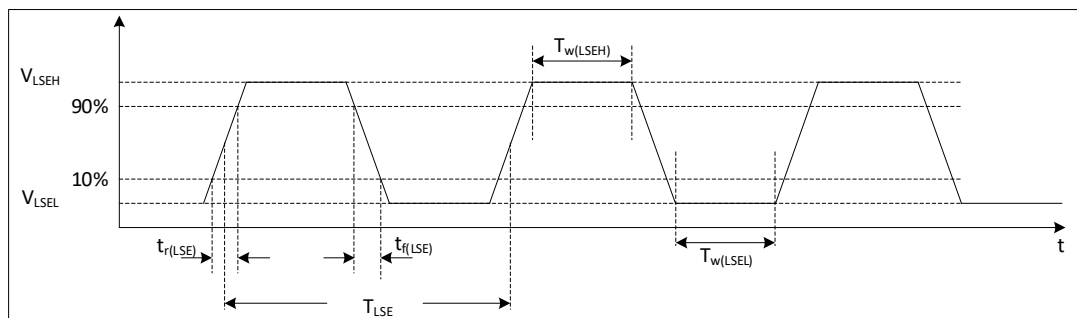

Figure 5-2 External low-speed clock timing diagram

Table 5-12 External low-speed clock characteristics

Symbol	Parameters ⁽¹⁾	Minimum	Typical	Maximum	Unit
f_{LSE_ext}	User external clock frequency	-	32.768	1000	KHz
V_{LSEH}	Input pin high level voltage	$0.7 V_{CC}$	-	-	V
V_{LSEL}	Input pin low level voltage	-	-	$0.3 V_{CC}$	V
$t_{w(LSEH)}$ $t_{w(LSEL)}$	Enter high or low time	450	-	-	ns
$t_{r(LSE)}$ $t_{f(LSE)}$	Enter the rise/fall time	-	-	50	ns

1. Guaranteed by design, not tested in production.

5.3.6.3. External high-speed crystal

The high-speed external (HSE) clock can be supplied with a ~32 MHz crystal/ceramic resonator oscillator. In the application, the resonator and the load capacitors have to be placed as close as possible to the oscillator pins in order to minimize output distortion and startup stabilization time.

Table 5-13 External high-speed crystal characteristics

Symbol	Parameter	Condition ⁽¹⁾	Minimum ⁽²⁾	Typical	Maximum ⁽²⁾	Unit
f_{OSC_IN}	Oscillation frequency	-	4	-	32	MHz
$I_{DD}^{(4)}$	HSE current consumption	During startup	-	-	5.5	mA
		$V_{CC} = 3 V, R_m = 30 \Omega, C_L = 10 pF @ 8 MHz$	-	0.58	-	
		$V_{CC} = 3 V, R_m = 45 \Omega, C_L = 10 pF @ 8 MHz$	-	0.59	-	
		$V_{CC} = 3 V, R_m = 30 \Omega, C_L = 5 pF @ 48 MHz$	-	0.89	-	
		$V_{CC} = 3 V, R_m = 30 \Omega, C_L = 10 pF @ 48 MHz$	-	1.14	-	
		$V_{CC} = 3 V, R_m = 30 \Omega, C_L = 20 pF @ 48 MHz$	-	1.94	-	
$t_{SU(HSE)}^{(3)(4)}$	Startup Time	$f_{OSC_IN} = 32 MHz$	-	2	-	ms
		$f_{OSC_IN} = 4 MHz$	-	2	-	

1. Crystal/ceramic resonator characteristics are based on the manufacturer's datasheet.
2. Guaranteed by design, not tested in production.

- $t_{SU(HSE)}$ is the startup time from enable (by software) to when the clock oscillation reaches a stable state, measured for a standard crystal/resonator, which can vary considerably from one crystal/resonator to another.
- Data is based on assessment results and is not tested in production.

5.3.6.4. External low speed crystal

The low-speed external (LSE) clock can be supplied with a 32.768 KHz crystal resonator oscillator. In the application, the resonator and the load capacitors have to be placed as close as possible to the oscillator pins in order to minimize output distortion and startup stabilization time.

Table 5-14 External low-speed crystal feature

Symbol	Parameter	Condition ⁽¹⁾	Minimum ⁽²⁾	Typical	Maximum ⁽²⁾	Unit
$I_{DD}^{(4)}$	LSE current consumption	LSE_DRIVER [1:0] = 00	-	250	-	nA
		LSE_DRIVER [1:0] = 01	-	560	-	
		LSE_DRIVER [1:0] = 10	-	920	-	
		LSE_DRIVER[1:0] = 11	-	1260	-	
$t_{SU(LSE)}^{(3)(4)}$	Startup Time	-	-	3	-	s

- Crystal/ceramic resonator characteristics are based on the manufacturer's datasheet.
- Guaranteed by design, not tested in production.
- $t_{SU(LSE)}$ is the startup time from enable (by software) to when the clock oscillation reaches a stable, measured for a standard crystal/resonator, which may vary greatly from crystal to resonator.
- Data is based on assessment results and is not tested in production.

5.3.7. Internal high frequency clock source HSI characteristics

Table 5-15 Internal high frequency clock source characteristics

Symbol	Parameter	Condition	Minimum	Typical	Maximum	Unit
f_{HSI}	HSI frequency	-	-	4.0 8.0 16.0 22.12 24.0	-	MHz
$\Delta T_{emp(HSI)}$	HSI frequency temperature drift	$V_{CC} = 1.7 \sim 5.5 V, T_A = 25 \text{ }^\circ\text{C}$	-1 ⁽²⁾	-	1 ⁽²⁾	%
		$V_{CC} = 1.7 \sim 5.5 V, T_A = 0 \sim 85 \text{ }^\circ\text{C}$	-2 ⁽²⁾	-	2 ⁽²⁾	
		$V_{CC} = 1.7 \sim 5.5 V, T_A = -40 \sim 85 \text{ }^\circ\text{C}$	-4 ⁽²⁾	-	2 ⁽²⁾	
		$V_{CC}=1.7 \sim 5.5 V, T_A=-40 \sim 105 \text{ }^\circ\text{C}$	-4 ⁽²⁾	-	4 ⁽²⁾	
$f_{TRIM}^{(1)}$	HSI fine-tuning accuracy	-	-	0.1	-	%
$\Delta T_{emp(HSI)}$	HSI frequency temperature drift	-	45 ⁽¹⁾	-	55 ⁽¹⁾	%
$t_{Stab(HSI)}$	HSI stabilization time	-	-	2	4 ⁽¹⁾	us
$f_{TRIM}^{(1)}$	HSI fine-tuning accuracy	4 MHz	-	110	-	uA
		8 MHz	-	120	-	
		16 MHz	-	170	-	
		22.12 MHz, 24 MHz	-	210	-	

- Guaranteed by design, not tested in production.
- Data is based on assessment results and is not tested in production.

5.3.8. Internal low frequency clock source LSI characteristics

Table 5-16 Internal low frequency clock characteristics

Symbol	Parameter	Condition	Minimum	Typical	Maximum	Unit
f _{LSI}	LSI frequency	-	-	32.768	-	kHz
ΔT _{emp(LSI)}	LSI frequency temperature drift	V _{CC} = 3.3 V, T _A = 25 °C	-3	-	+3	%
		V _{CC} = 1.7 to 5.5 V, T _A = 0 ~ 85 °C	-10 ⁽²⁾	-	10 ⁽²⁾	
		V _{CC} =1.7 ~ 5.5 V, T _A =0 ~ 105 °C	- 15 ⁽²⁾	-	15 ⁽²⁾	
		V _{CC} =1.7 ~ 5.5 V, T _A =-40 ~ 105 °C	- 20 ⁽²⁾	-	20 ⁽²⁾	
f _{TRIM} ⁽¹⁾	LSI fine-tuning accuracy	-	-	0.2	-	%
t _{Stab(LSI)} ⁽¹⁾	LSI stabilization time	-	-	150	-	us
I _{DD(LSI)} ⁽¹⁾	LSI current consumption	-	-	300	-	nA

1. Guaranteed by design, not tested in production.
2. Data is based on assessment results and is not tested in production.

5.3.9. Phase locked loop (PLL) characteristics

Table 5-17 Phase locked loop characteristics

Symbol	Parameter	Condition	Minimum	Typical	Maximum	Unit
f _{PLL_IN}	Input frequency	T _A = 25 °C, V _{CC} = 3.3 V PLL 2x	16 ⁽¹⁾	-	24 ⁽¹⁾	MHz
		T _A = 25 °C, V _{CC} = 3.3 V PLL 3x	22.12 ⁽¹⁾	-	24 ⁽¹⁾	
f _{PLL_OUT}	Output frequency	T _A = 25 °C, V _{CC} = 3.3 V	32 ⁽¹⁾	-	72	MHz
Jitter	Period jitter	-	-	-	0.3 ⁽¹⁾	ns
t _{LOCK}	Latch time	f _{PLL_IN} = 24 MHz	-	15	40 ⁽¹⁾	us

1. Guaranteed by design, not tested in production.

5.3.10. Memory characteristics

Table 5-18 Memory characteristics

Symbol	Parameter	Condition	Typical	Maximum ⁽¹⁾	Unit
t _{prog}	Page program	-	1.0	1.5	ms
t _{ERASE}	Page/sector/mass erase	-	3.5	4.5	ms
I _{DD}	Page programe	-	2.1	2.9	mA
	Page/sector/mass erase	-	2.1	2.9	mA

1. Guaranteed by design, not tested in production.

Table 5-19 Memory erase times and data retention

Symbol	Parameter	Condition	Minimum ⁽¹⁾	Unit
N _{END}	Erase and write times	T _A = -40 to 85 °C	100	kcycle
		T _A = 85 ~ 105 °C	10	
t _{RET}	Data retention period	10 Kcycle T _A = 55 °C	20	Year

1. Data is based on assessment results and is not tested in production.

5.3.11. EFT characteristics

Table 5-20 EFT characteristics

Symbol	Parameter	Condition	Grade	Typical	Unit
EFT to Power	-	IEC61000-4-4	B	4	kV

5.3.12. ESD & LU characteristics

Table 5-21 ESD & LU characteristics

Symbol	Parameter	Condition	Typical	Unit
$V_{ESD(HBM)}$	Static discharge voltage (human body model)	ESDA/JEDEC JS-001-2017	7.5	kV
$V_{ESD(CDM)}$	Static discharge voltage (charging equipment model)	ESDA/JEDEC JS-002-2018	1	kV
$V_{ESD(MM)}$	Static discharge voltage (machine model)	JESD22-A115C	200	V
LU	Static latch-up	JESD78E	200	mA

5.3.13. Port characteristics

Table 5-22 IO static characteristics

Symbol	Parameter	Condition	Minimum	Typical	Maximum	Unit
V_{IH}	Input high level voltage	$V_{CC} = 1.7$ to 5.5 V	$0.7 V_{CC}$	-	-	V
V_{IL}	Input low level voltage	$V_{CC} = 1.7$ to 5.5 V	-	-	$0.3 V_{CC}$	V
$V_{hys}^{(1)}$	Schmitt hysteresis voltage	-	-	200	-	mV
I_{lkg}	Input leakage current	-	-	-	1	μ A
R_{PU}	Pull-up resistor	-	30	50	70	$k\Omega$
R_{PD}	Pull-down resistor	-	30	50	70	$k\Omega$
$C_{IO}^{(1)}$	Pin capacitance	-	-	5	-	pF

1. Guaranteed by design, not tested in production.

Table 5-23 Output voltage characteristics

Symbol	Parameters ⁽¹⁾	Condition	Minimum	Maximum	Unit
V_{OL}	COM IO output low level	$I_{OL} = 8$ mA, $V_{CC} \geq 2.7$ V	-	0.4	V
V_{OL}		$I_{OL} = 4$ mA, $V_{CC} = 1.8$ V	-	0.5	V
$V_{OL}^{(3)}$	Output low level voltage for an I/O pin	$I_{OL} = 8$ mA, $V_{CC} \geq 2.7$ V	-	0.4	V
$V_{OL}^{(3)}$		$I_{OL} = 4$ mA, $V_{CC} = 1.8$ V	-	0.4	V
V_{OH}	COM IO output high level	$I_{OH} = 8$ mA, $V_{CC} \geq 2.7$ V	$V_{CC}-0.4$	-	V
V_{OH}		$I_{OH} = 4$ mA, $V_{CC} = 1.8$ V	$V_{CC}-0.5$	-	V
$V_{OH}^{(3)}$	Output high level voltage for an I/O pin	$I_{OL} = 8$ mA, $V_{CC} \geq 2.7$ V	$V_{CC}-0.4$	-	V
$V_{OH}^{(3)}$		$I_{OL} = 4$ mA, $V_{CC} = 1.8$ V	$V_{CC}-0.4$	-	V

1. IO types can refer to the terms and symbols defined by the pins.
2. Data is based on assessment results and is not tested in production.

5.3.14. NRST pin characteristics

Table 5-24 NRST pin characteristics

Symbol	Parameter	Condition	Minimum	Typical	Maximum	Unit
V_{IH}	Input high level voltage	$V_{CC} = 1.7$ to 5.5 V	$0.7 V_{CC}$	-	-	V
V_{IL}	Input low level voltage	$V_{CC} = 1.7$ to 5.5 V	-	-	$0.2 V_{CC}$	V
$V_{hys}^{(1)}$	Schmitt hysteresis voltage	-	-	200	-	mV
I_{lkg}	Input leakage current	-	-	-	1	uA
$R_{PU}^{(1)}$	Pull-up resistor	-	30	50	70	k Ω
$R_{PD}^{(1)}$	Pull-down resistor	-	30	50	70	k Ω
$C_{IO_}$	Pin capacitance	-	-	5	-	pF

1. Guaranteed by design, not tested in production.

5.3.15. ADC characteristics

Table 5-25 ADC characteristics

Symbol	Parameter	Condition	Minimum	Typical	Maximum	Unit
I_{CC}	Current consumption	@0.75MSPS	-	0.4	-	mA
$C_{IN}^{(1)}$	Internal sample and hold capacitors	-	-	5	8	pF
F_{ADC}	Convert clock frequency	$V_{CC} = 1.7$ to 2.3 V	1	4	$8^{(2)}$	MHz
		$V_{CC} = 2.3$ to 5.5 V	1	8	$16^{(2)}$	MHz
$t_{smp}^{(1)}$	-	$V_{CC} = 1.7$ to 2.3 V	$3.5 * T_{clk}$	-	$41.5 * T_{clk}$	-
$t_{conv}^{(1)}$	-	-	-	$12 * T_{clk}$	-	-
$t_{eoc}^{(1)}$	-	-	-	$0.5 * T_{clk}$	-	-
$DNL^{(2)}$	RT	-	-	± 1	$-1 \sim 1.5$	LSB
$INL^{(2)}$	RT	-	-	-	± 3	LSB
Offset ⁽²⁾	RT	-	-	± 1.5	± 3	LSB

1. Guaranteed by design, not tested in production.

2. Data is based on assessment results and is not tested in production.

5.3.16. Comparator characteristics

Table 5-26 Comparator characteristics⁽¹⁾

Symbol	Parameter	Condition	Minimum	Typical	Maximum	Unit	
V_{IN}	Input voltage range	-	0	-	V_{CC}	V	
V_{SC}	Scaler offset voltage	-	-	± 5	± 10	mV	
$I_{DD}(\text{SCALER})$	Scaler static consumption	-	-	0.8	1	uA	
t_{START_SCALER}	Scaler startup time	-	-	100	200	us	
t_{START}	Startup time to reach propagation delay specification	High-speed mode	-	-	5	us	
		Medium-speed mode	-	-	15		
t_D	Propagation delay	200 mV step, 100 mV overdrive	High-speed mode	-	40	70	ns
			Medium-speed mode	-	0.9	2.3	us
		>200 mV step,	High-speed mode	-	-	85	ns

Symbol	Parameter	Condition		Minimum	Typical	Maximum	Unit
		100 mV overdrive	Medium-speed mode	-	-	3.4	us
V_{offset}	Offset error	-		-	±5	-	mV
V_{hys}	Hysteresis	No hysteresis		-	0	-	mV
		With hysteresis		-	20	-	
I_{DD}	Consumption	Medium-speed mode, no de-glitched	Static	-	5	-	uA
			With 50 KHz and ±100 mv overdrive square signal	-	6	-	uA
		Medium-speed mode, with de-glitched	Static	-	7	-	uA
			With 50 KHz and ±100 mv overdrive square signal	-	8	-	uA
		High-speed mode, no de-glitched	Static	-	250	-	uA
			With 50 KHz and ±100 mv overdrive square signal	-	250	-	uA

1. Guaranteed by design, not tested in production.

5.3.17. Operational amplifier characteristics

Table 5-27 Operational amplifier characteristics

Symbol	Parameter	Condition	Minimum	Typical	Maximum	Unit
V_i	Input voltage	-	0	-	AV_{CC}	V
V_o	The output voltage	-	0.1	-	$AV_{\text{CC}} - 0.2$	V
I_o	Output current	-	-	-	2.2	mA
R_L	load time	-	5K	-	-	Ω
t_{start}	Initialization time	-	-	-	20	us
V_{io}	Input offset voltage	-	-	±6	-	mV
PM	Phase margin	-	-	80	-	Deg
UGBW	Unity gain width	-	-	10	-	MHz
SR	Slew rate	-	-	8	-	V/us

5.3.18. Temperature sensor characteristics

Table 5-28 Temperature sensor characteristics

Symbol	Parameter	Minimum	Typical	Maximum	Unit
$T_L^{(1)}$	V_{TS} linearity with temperature	-	± 1	± 2	$^{\circ}\text{C}$
Avg_Slope ⁽¹⁾	Average slope	2.3	2.5	2.7	mV/ $^{\circ}\text{C}$
V_{30}	Voltage at 30 $^{\circ}\text{C}$ (± 5 $^{\circ}\text{C}$)	0.742	0.76	0.785	V
$t_{\text{START}}^{(1)}$	Start up time entering in continuous mode	-	70	120	us
$t_{s_temp}^{(1)}$	ADC sampling time when reading the temperature	9	-	-	us

1. Guaranteed by design, not tested in production.
2. Data is based on assessment results and is not tested in production.

5.3.19. Built-in reference voltage characteristics

Table 5-29 Built-in reference voltage characteristics

Symbol	Parameter		Minimum	Typical	Maximum	Unit
V_{REFINT}	Internal reference voltage		1.17	1.2	1.23	V
$t_{\text{start_vrefint}}$	Start time of internal reference voltage		-	10	15	us
T_{coeff}	Temperature coefficient		-	-	100 ⁽¹⁾	ppm/ $^{\circ}\text{C}$
I_{VCC}	Current consumption from V_{CC}		-	12	20	μA
T_{coeff}	Internal 2.5 V/1.5 V temperature coefficient	$T_A = -40 \sim 105^{\circ}\text{C}$	-	-	120	ppm/ $^{\circ}\text{C}$

1. Guaranteed by design, not tested in production.

5.3.20. Timer characteristics

Table 5-30 Timer characteristics

Symbol	Parameter	Condition	Minimum	Maximum	Unit
$t_{\text{res}}(\text{TIM})$	Timer resolution time	-	1	-	t_{TIMxCLK}
		$f_{\text{TIMxCLK}} = 72 \text{ MHz}$	13.889	-	ns
f_{EXT}	Timer external clock frequency on CH1 to CH4	-	-	$f_{\text{TIMxCLK}}/2$	MHz
		$f_{\text{TIMxCLK}} = 72 \text{ MHz}$	-	24	
Res_{TIM}	Timer resolution	TIM1/3/14/15/16/17	-	16	Bit
t_{COUNTER}	16 bits counter clock period	-	1	65536	t_{TIMxCLK}
		$f_{\text{TIMxCLK}} = 72 \text{ MHz}$	0.013889	913	us

Table 5-31 LPTIM characteristics (clock selection LSI)

Prescaler	PRESC[2:0]	Minimum overflow	Maximum overflow	Unit
/1	0	0.0305	1998.848	ms
/2	1	0.0610	3997.696	
/4	2	0.1221	8001.9456	
/8	3	0.2441	15997.3376	
/16	4	0.4883	32001.2288	
/32	5	0.9766	64002.4576	
/64	6	1.9531	127998.3616	
/128	7	3.9063	256003.2768	

Table 5-32 IWDG characteristics (clock selection LSI)

Prescaler	PR[2:0]	Minimum overflow	Maximum overflow	Unit
/4	0	0.122	499.712	ms
/8	1	0.244	999.424	
/16	2	0.488	1998.848	
/32	3	0.976	3997.696	
/64	4	1.952	7995.392	
/128	5	3.904	15990.784	
/256	6 or 7	7.808	31981.568	

Table 5-33 WWDG characteristics (Clock selection 4 8MHz PCLK)

Prescaler	WDGTB[1:0]	Minimum overflow	Maximum overflow	Unit
1*4096	0	0.085	5.461	ms
2*4096	1	0.171	10.923	
4*4096	2	0.341	21.845	
8*4096	3	0.683	43.691	

5.3.21. Communication port characteristics

5.3.21.1. I²C bus interface features

The I²C interface meets the timing requirements of the I²C-bus specification and user manual:

- Standard-mode (Sm): 100 kbit/s
- Fast-mode (Fm): 400 kbit/s

The I²C timings requirements is guaranteed by design, provided the I²C peripheral is properly configured and the I²C CLK frequency is greater than the minimum required in the table below.

Table 5-34 Minimum I²C CLK frequency

Symbol	Parameter	Condition	Minimum	Unit
f _{I2CCLK(min)}	Minimum I ² C CLK frequency	Standard-mode	2	MHz
		Fast-mode	9	

I²C SDA and SCL pins have analogue filtering, see table below.

Table 5-35 I²C filter characteristics

Symbol	Parameter	Minimum	Maximum	Unit
t _{AF}	Limiting duration of spikes suppressed by the filter (spikes shorter than the limiting duration are suppressed)	50	260	ns

5.3.21.2. Serial peripheral interface (SPI) characteristics

Table 5-36 SPI characteristics

Symbol	Parameter	Condition	Minimum	Maximum	Unit
f _{SCK} 1/t _{c(SCK)}	SPI clock frequency	Master mode	-	24	MHz
		Slave mode	-	18	
t _{r(SCK)} t _{f(SCK)}	SPI clock rise and fall time	Capacitive load: C = 15 pF	-	6	ns
t _{su(NSS)}	NSS setup time	Slave mode	4 T _{pclk}	-	ns
t _{h(NSS)}	NSS hold time	Slave mode	2 T _{pclk} + 10	-	ns
t _{w(SCKH)} t _{w(SCKL)}	SCK high and low time	Master mode, presc = 4	T _{pclk} *2 - 2	T _{pclk} *2 + 1	ns
t _{su(MI)}	Data input setup time	Master mode, presc = 4	T _{pclk} + 5 ⁽¹⁾	-	ns

Symbol	Parameter	Condition	Minimum	Maximum	Unit
$t_{su(SI)}$		Slave mode, presc = 4	5	-	
$t_{h(MI)}$	Data input hold time	Master mode	5	-	ns
$t_{h(SI)}$		Slave mode	$T_{pclk} + 5$	-	
$t_{a(SO)}$	Data output access time	Slave mode, presc = 4	0	$3T_{pclk}$	ns
$t_{dis(SO)}$	Data output disable time	Slave mode	$2T_{pclk} + 5$	$4T_{pclk} + 5$	ns
$t_{v(SO)}$	Data output valid time	Slave mode (after enable edge), presc = 4	0	$1.5T_{pclk}^{(2)}$	ns
$t_{v(MO)}$	Data output valid time	Master mode (after enable edge)	-	6	ns
$t_{h(SO)}$	Data output hold time	Slave mode, presc = 4	$0^{(3)}$	-	ns
$t_{h(MO)}$		Master mode	2	-	
DuCy(SCK)	SPI slave input clock duty cycle	Slave mode	45	55	%

1. The Master generates a 1 pclk receive control signal before the receive edge.
2. Slave has a maximum of 1 pclk based on the sending edge of SCK delay, considering IO delay, etc., define 1.5 pclk.
3. Between the receiving edge and the sending edge, the slave updates the data before the sending edge.

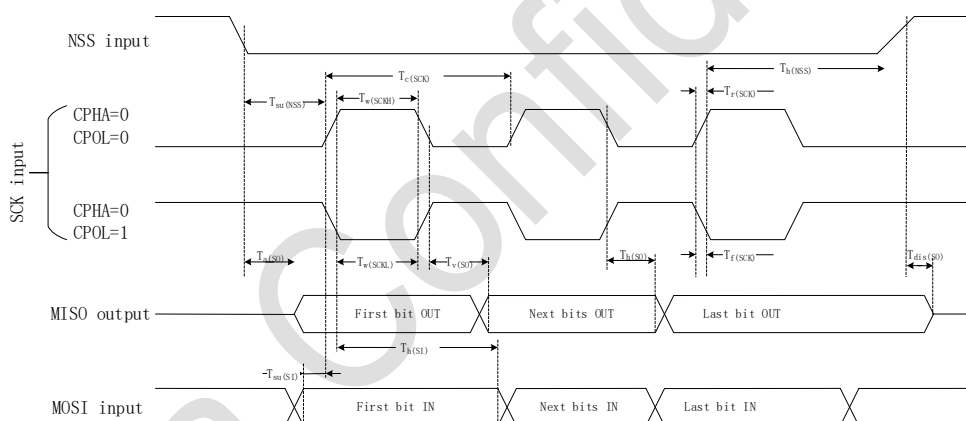

Figure 5-3 SPI timing diagram – slave mode and CPHA=0

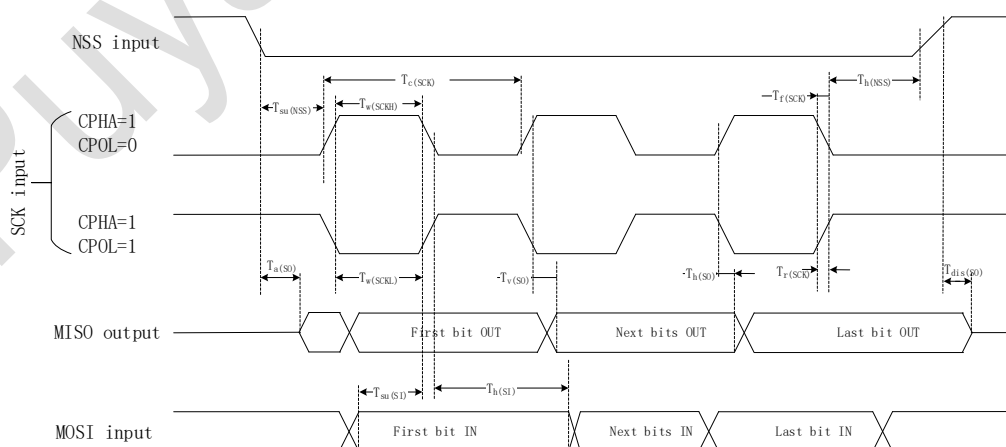

Figure 5-4 SPI timing diagram – slave mode and CPHA=1

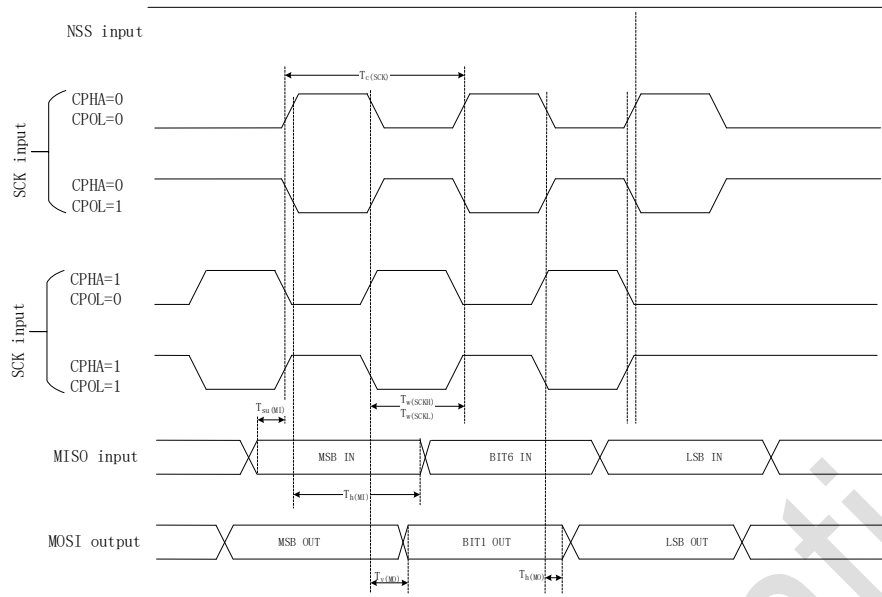
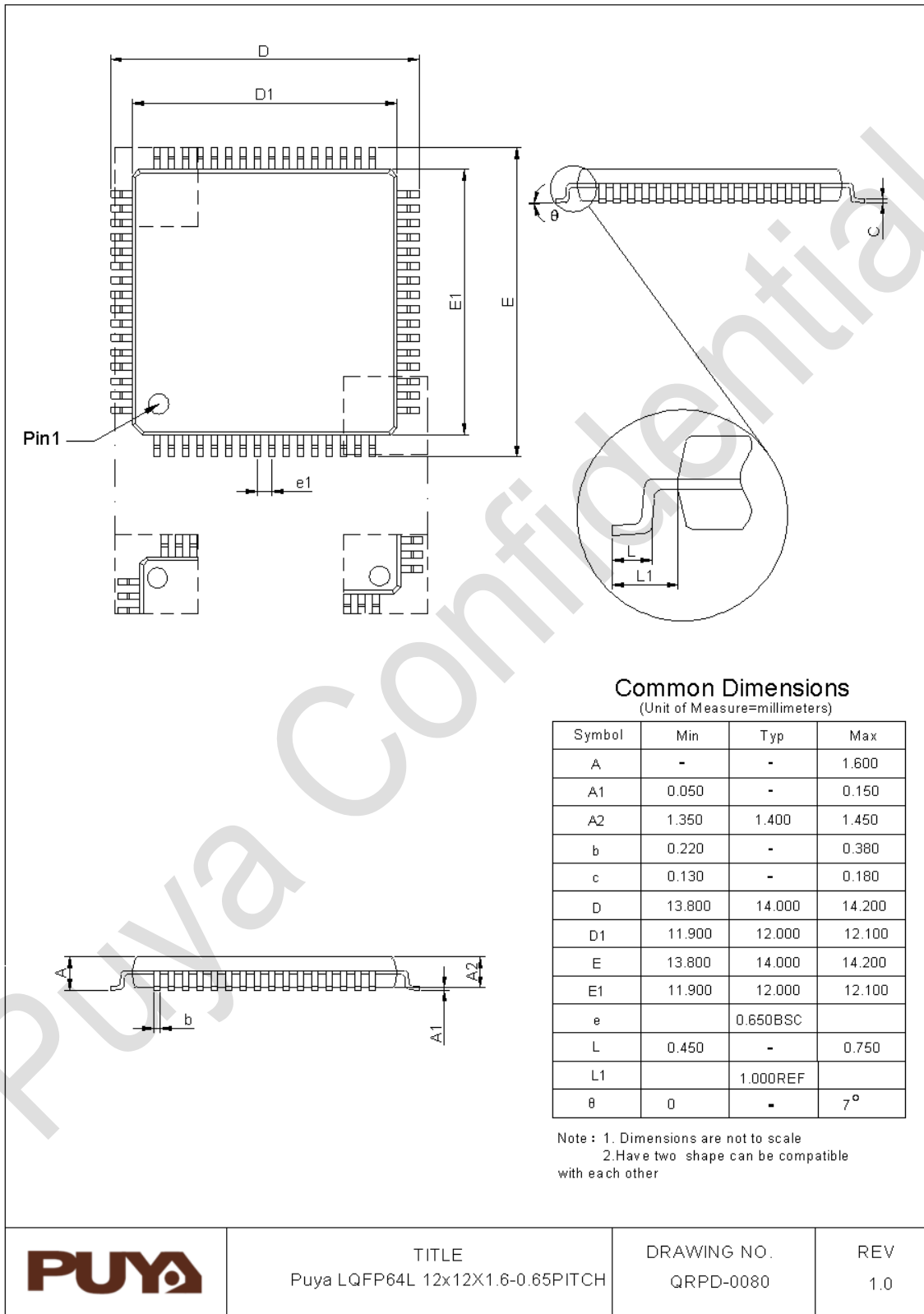

Figure 5-5 SPI timing diagram – master mode

Puya Confidential

6. Package Information

6.1. LQFP64 (12*12) package size



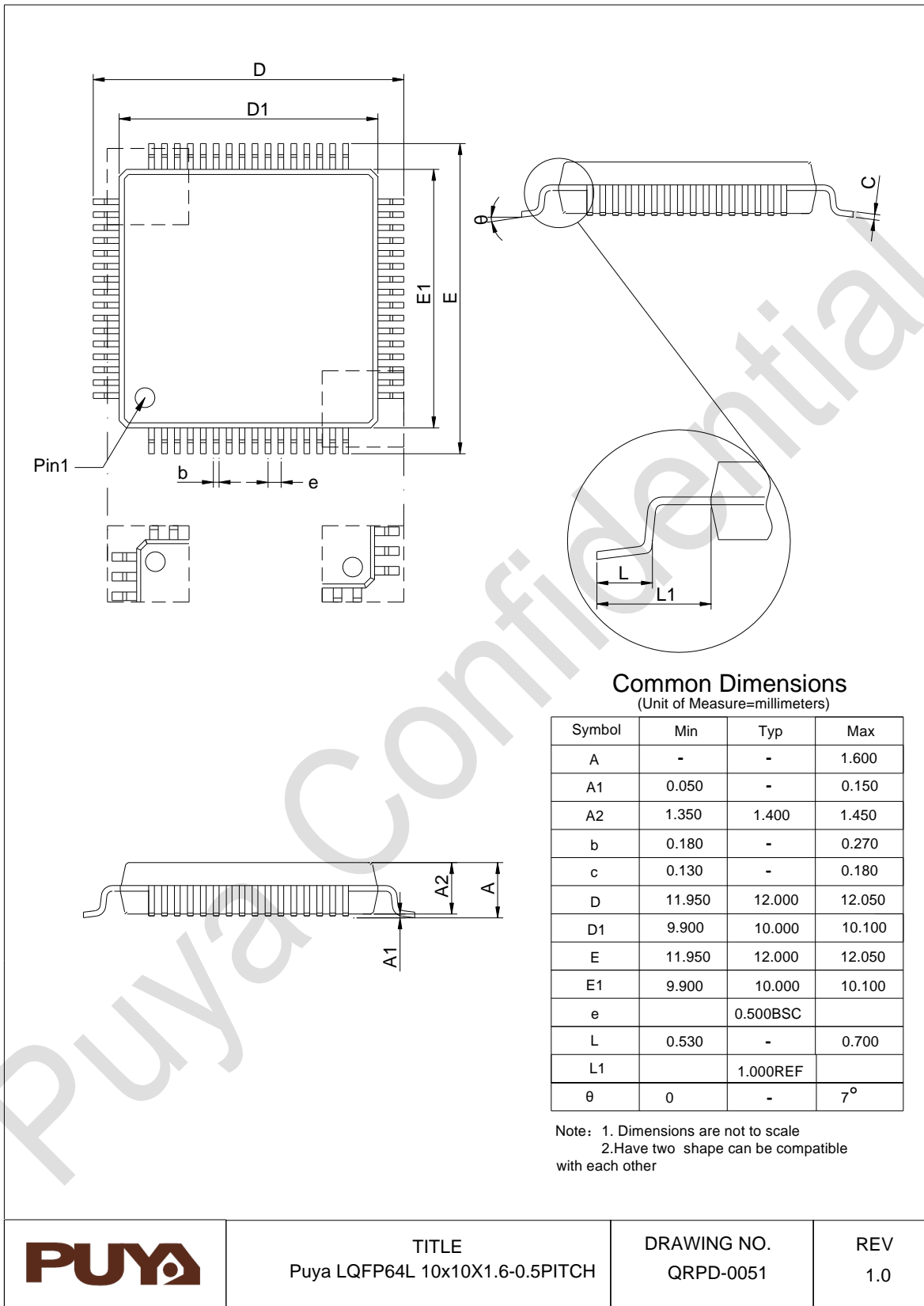

6.2. LQFP64(10*10) package size

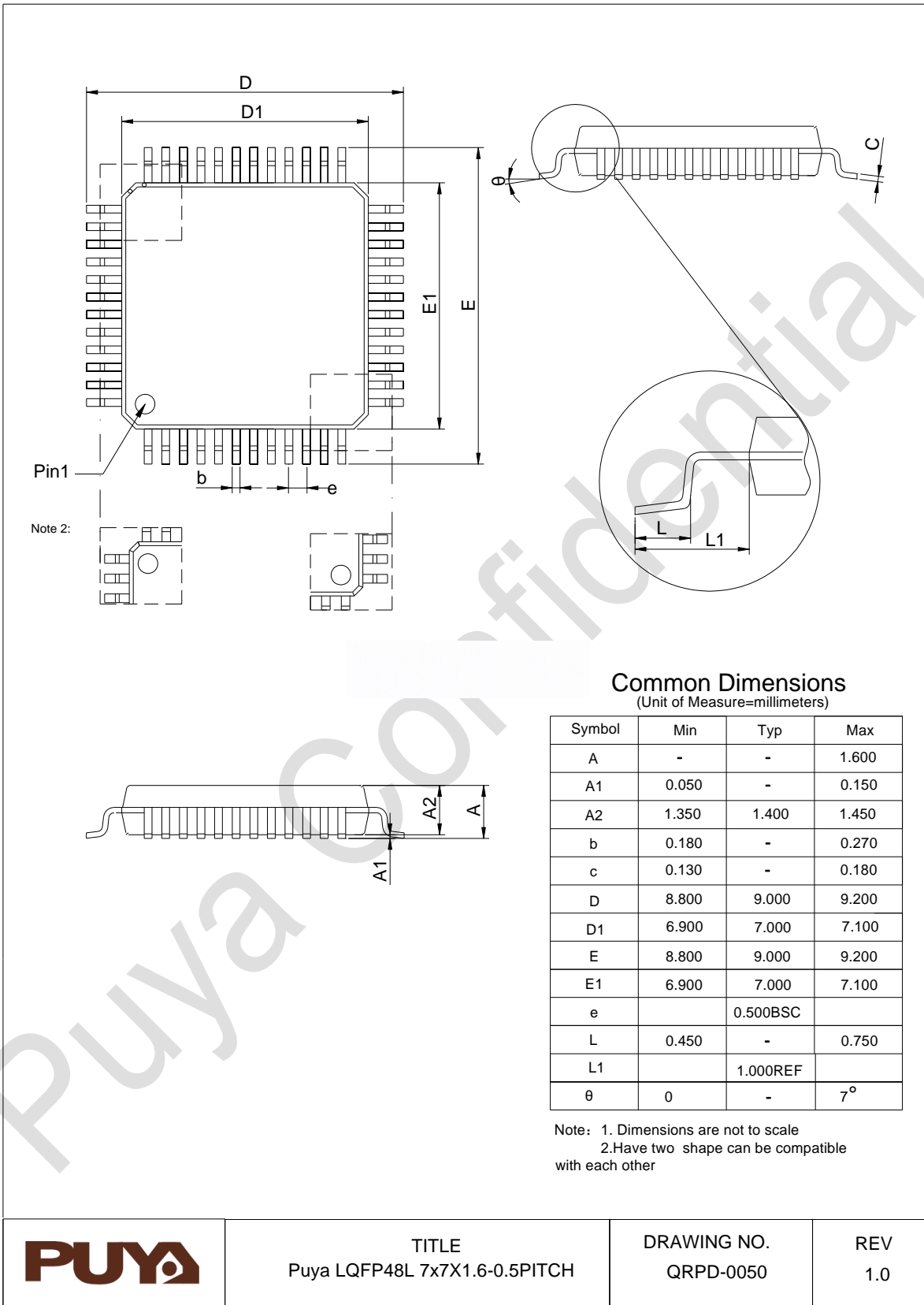

	TITLE	DRAWING NO.	REV
	Puya LQFP64L 10x10X1.6-0.5PITCH	QRPD-0051	1.0

6.3. LQFP48 package size



	<p>TITLE Puya LQFP48L 7x7X1.6-0.5PITCH</p>	<p>DRAWING NO. QRPD-0050</p>	<p>REV 1.0</p>
---	--	----------------------------------	--------------------

6.4. QFN48 package size

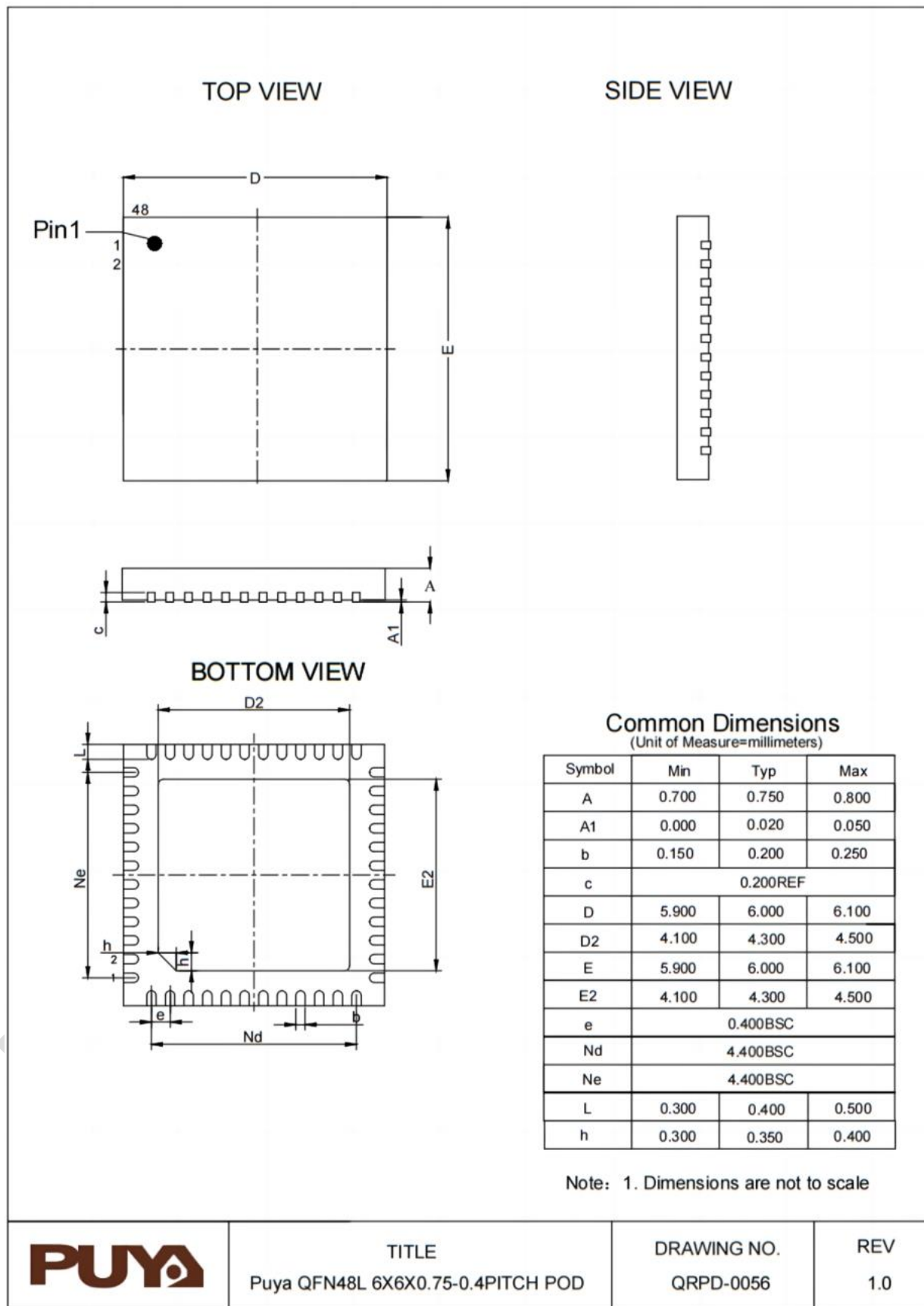

6.5. QFN32 (5*5) package size

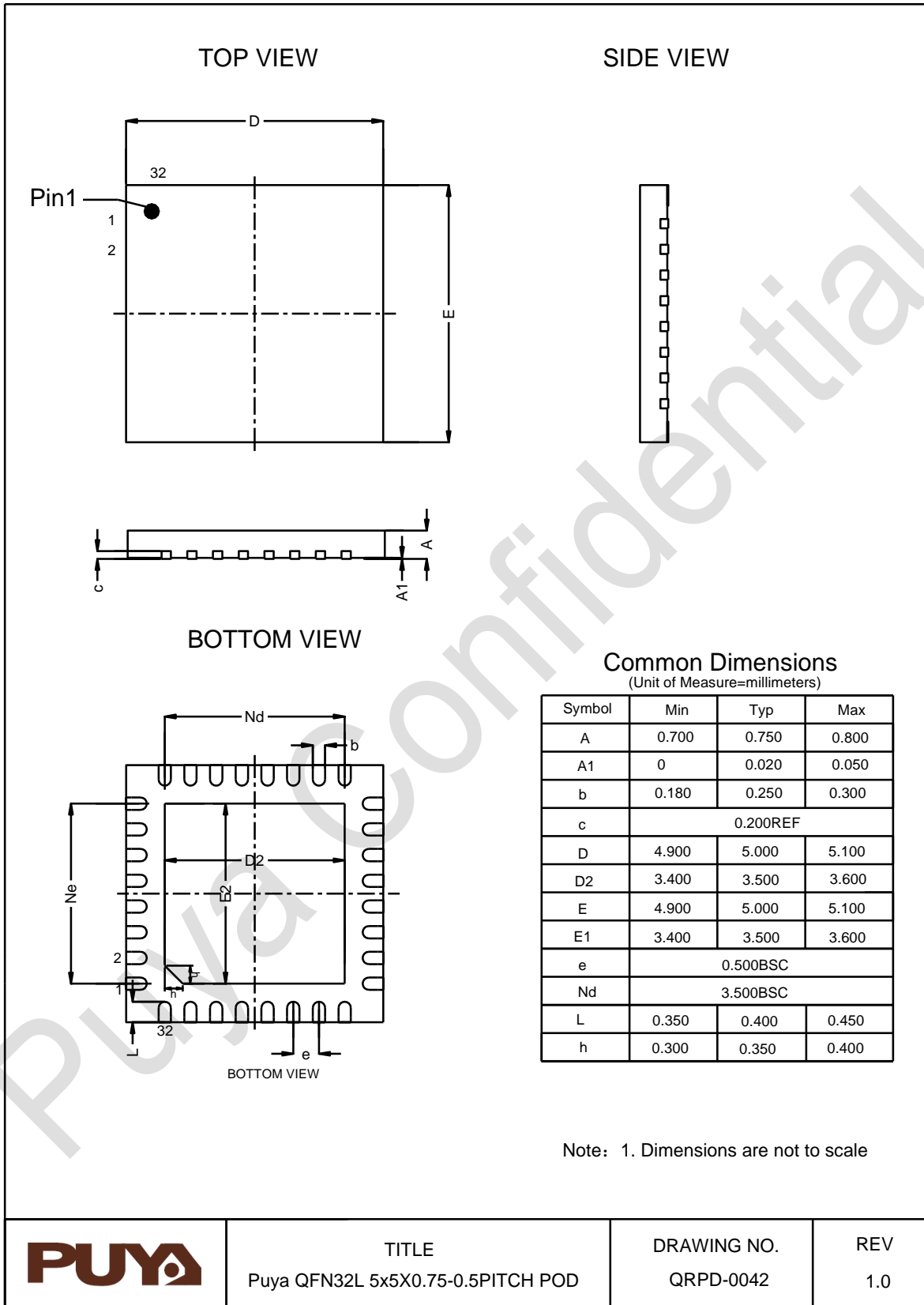

6.6. QFN32 (4*4) package size

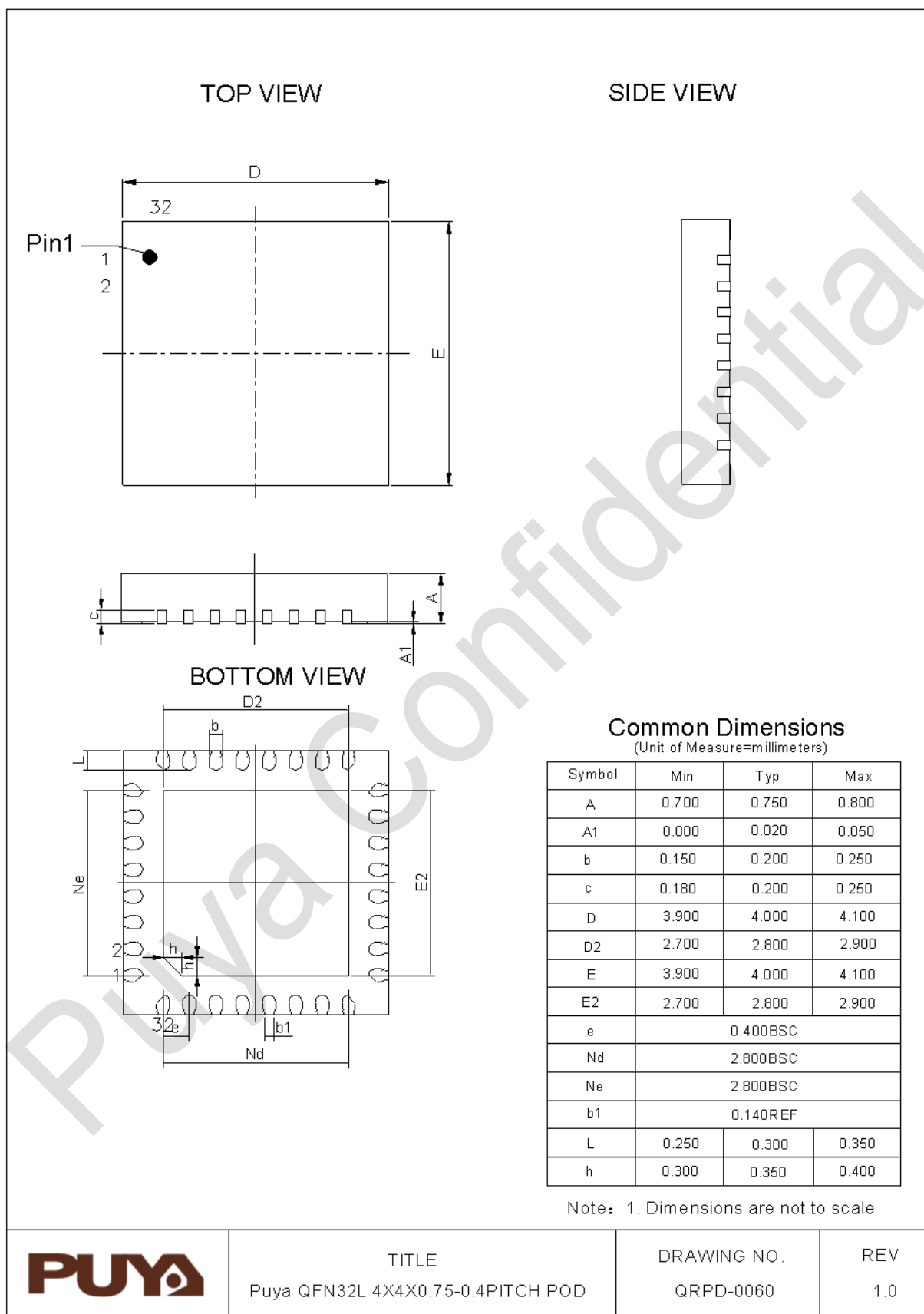

7. Ordering Information

Example:	PY	32	F	040	C1	8	T	6	x
<u>Company</u>									
<u>Product family</u> 32 bits MCU									
<u>Product type</u> F = General purpose									
<u>Sub-family</u> 040 = PY32F040xx									
<u>Pin count</u>									
R1 = 64 pins Pinout1 R2 = 64 pins Pinout2 C1 = 48 pins Pinout1 K1 = 32 pins Pinout1 K2 = 32 pins Pinout2									
<u>User code memory size</u>									
B = 128 Kbytes 8 = 64 Kbytes 6 = 32 Kbytes									
<u>Package</u>									
U = QFN T = LQFP									
<u>Temperature range</u>									
6 = -40°C to + 85°C 7 = -40°C to + 105°C									
<u>Options</u>									
xxx = Code ID of programmed parts(includes packing type) TR = Tape and reel packing TU = Tube Packing blank = Tray packing									

8. Version History

Version	Date	Updated record
V0.1	2022.12.16	Initial version
V0.2	2023.01.16	Updated Table 1-1
V0.3	2023.05.10	Updated Table 3-1
V0.4	2023.12.21	Updated Table 5-7, Table 5-8, Table 5-9
V0.5	2024.01.16	Updated Table 3-2
V0.6	2024.02.20	1. Add QFN48 package 2. Updated Table 3-2 3. Updated Table 1-1
V0.7	2024.04.24	1. Add LQFP64 (12*12) package 2. Updated Table 5-17 / 5-21
V0.8	2024.05.13	1. Add PY32F040x7 version product($T_A=105\text{ }^{\circ}\text{C}$) 2. Updated Table 5-20 / 5-36



Puya Semiconductor Co., Ltd.

IMPORTANT NOTICE

Puya reserve the right to make changes, corrections, enhancements, modifications to Puya products and/or to this document at any time without notice. Purchasers should obtain the latest relevant information of Puya products before placing orders.

Puya products are sold pursuant to terms and conditions of sale in place at the time of order acknowledgement.

Purchasers are solely responsible for the choice and use of Puya products. Puya does not provide service support and assumes no responsibility when products that are used on its own or designated third party products.

Puya hereby disclaims any license to any intellectual property rights, express or implied.

Resale of Puya products with provisions inconsistent with the information set forth herein shall void any warranty granted by Puya.

Any with Puya or Puya logo are trademarks of Puya. All other product or service names are the property of their respective owners.

The information in this document supersedes and replaces the information in the previous version.

Puya Semiconductor Co., Ltd. – All rights reserved